

automotive  
**testing** expo 2005  
europe



31 MAY & 1, 2 JUNE 2005 MESSE STUTT GART, GERMANY

**Optimization and reduction of  
testing expenditure with the  
help of a VeHiL test rig**

J. Schenk

**Technologies - Systems - Solutions**

## Agenda

- **Why do we develop vehicle test procedures for the future... ?**
  - The EU Projects PEIT and SPARC
- **Metamorphosis of the conventional V - Shape Process (VDI 2206)**
  - Ascendancies on the development process of new vehicles and components
- **VeHiL - Vehicle (Hardware) in the Loop**
  - Configuration of the VeHiL – Function Tester (HGV / passenger cars)
  - Potentials of the VeHiL within the vehicle development process
  - Vantages of the VeHiL within the vehicle production (Line Assembly)

# Why do we develop Vehicle Test Procedures for the future ?

Neue Offenheit  
lockt deutsche  
Zulieferer

**50% Reduction of Killed & Injured caused by Traffic up to 2010**

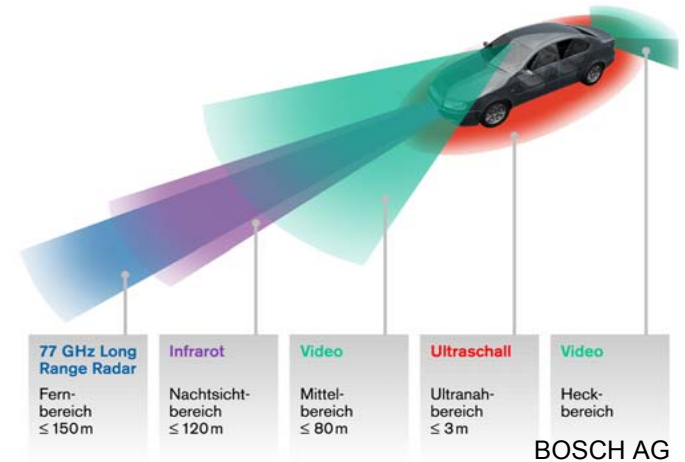

40 % with warning (Assistant) Systems

60 % with active Control Systems

**Environment Sensor Systems  
Radar, Lidar, Camera, IR, GPS, ...**

# Why do we develop Vehicle Test Procedures for the future ?



## Test- & Calibration P...

- more System
- sh
- and the
- Departure Warning
- Rear View Systems
- Reliability of new Systems
  - Superposition Steering
  - ESP- Plus, Brake-by-Wire Systems

**Attention !!!**  
**System Overload is imminent !**

More and more Systems → more and more Control Units → increasing Cross Links → exponential increasing Error Rate

## Why do we develop Vehicle Test Procedures for the future ?

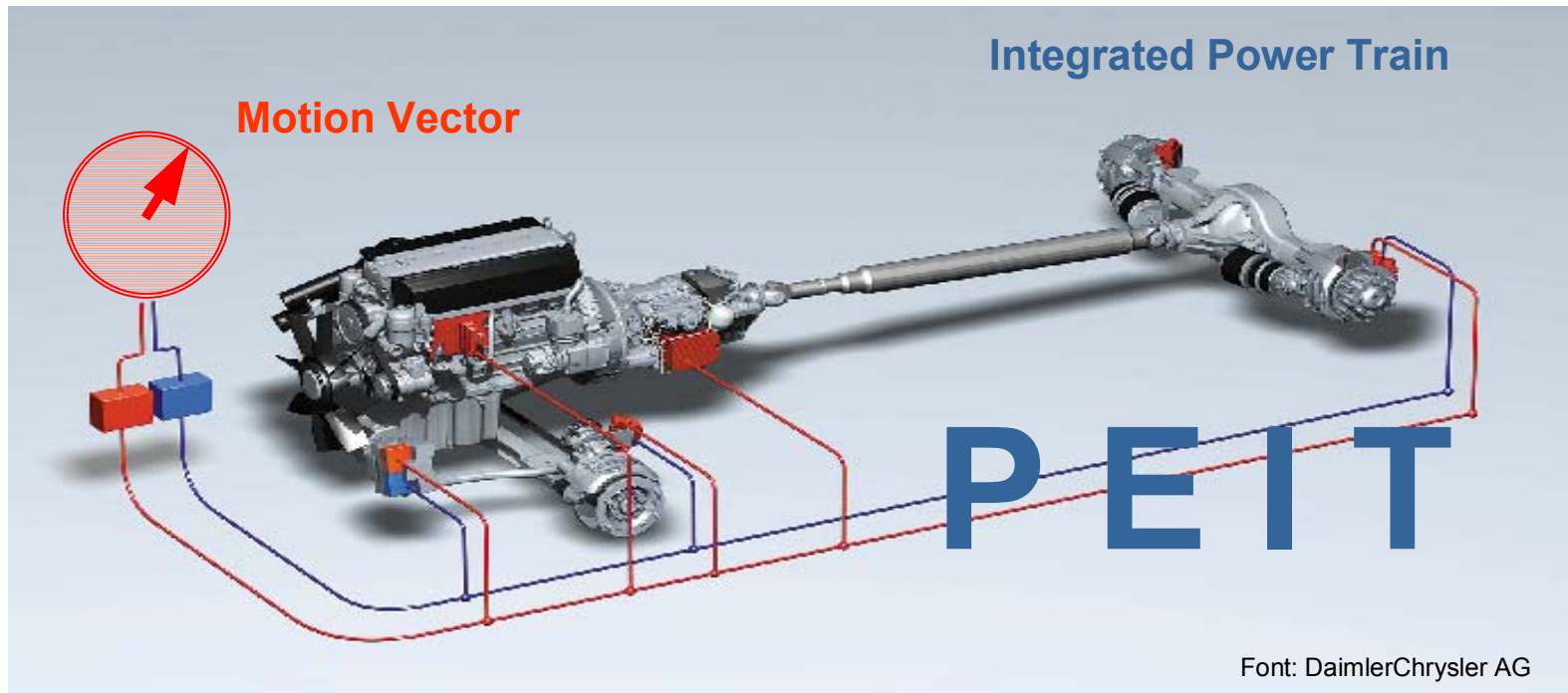

System Functions like ESP, ACC, LDW will be transmitted to the Power Train  
as pure Software based Algorithms

# Why do we develop Vehicle Test Procedures for the future ?



**Possible Build**  
**Vehicles**

(...abilities)

...MS

...rsal" Hardware

➤ Use of SCALE-Effects

**The Tests of Vehicles and their Components will be changing significantly !**

**SPARC**

## Agenda

- **Why do we develop vehicle test procedures for the future... ?**
  - The EU Projects PEIT and SPARC
- **Metamorphosis of the conventional V - Shape Process (VDI 2206)**
  - Ascendancies on the development process of new vehicles and components
- **VeHiL - Vehicle (Hardware) in the Loop**
  - Configuration of the VeHiL – Function Tester (HGV / passenger cars)
  - Potentials of the VeHiL within the vehicle development process
  - Vantages of the VeHiL within the vehicle production (Line Assembly)

# Metamorphosis of the conventional V-Shape Process

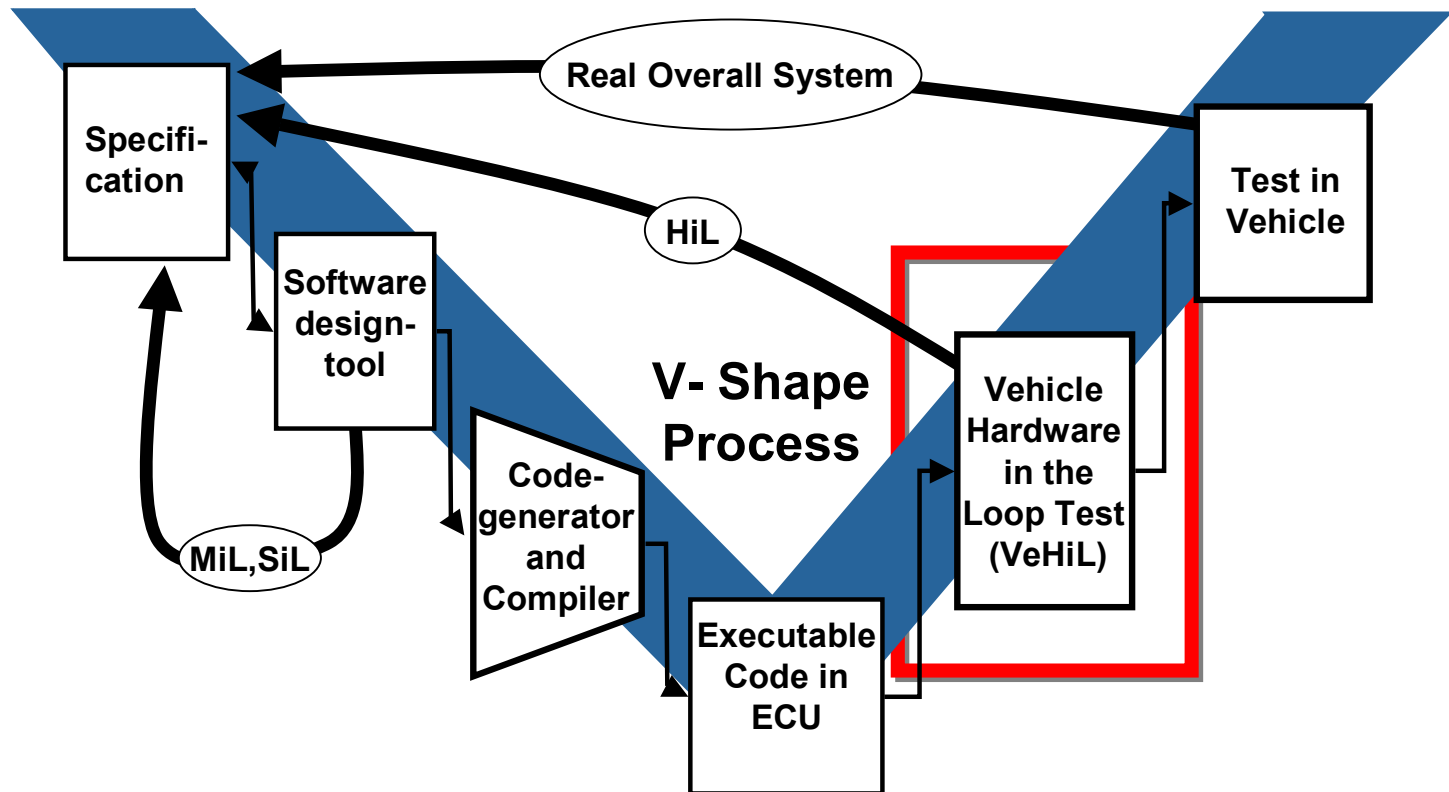

# Metamorphosis of the conventional V-Shape Process

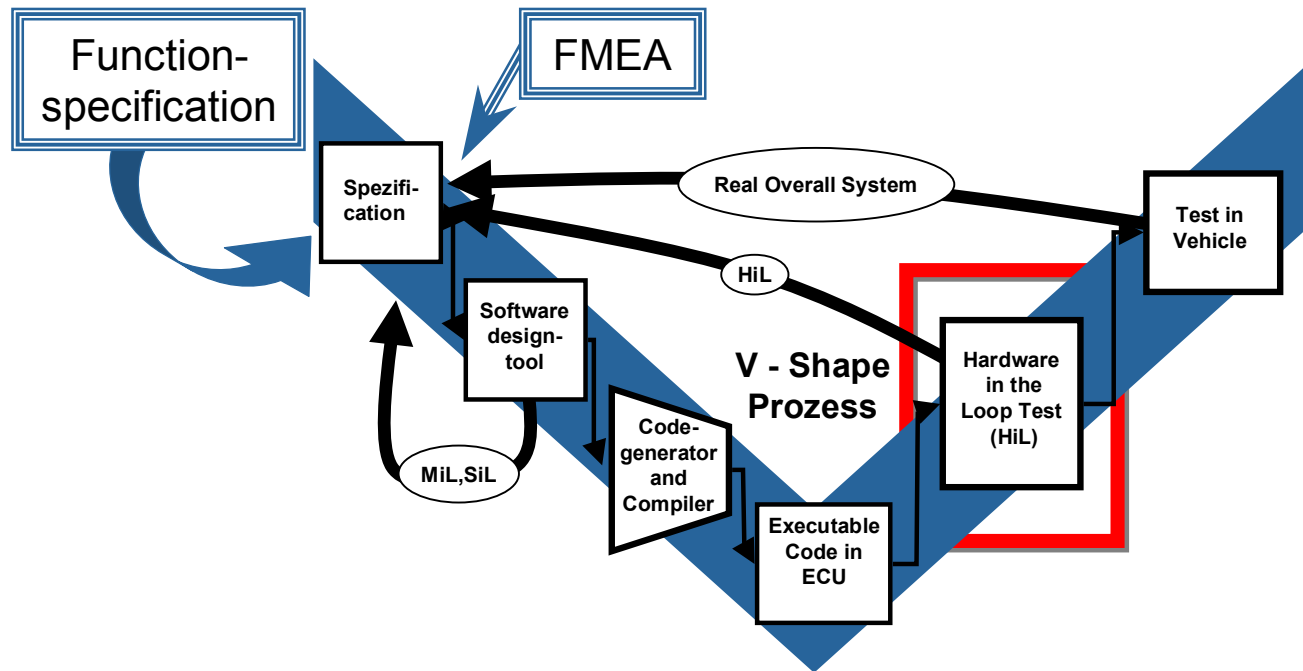

Future vehicles may run mainly based on software algorithms !!!



# Metamorphosis of the conventional V-Shape Process

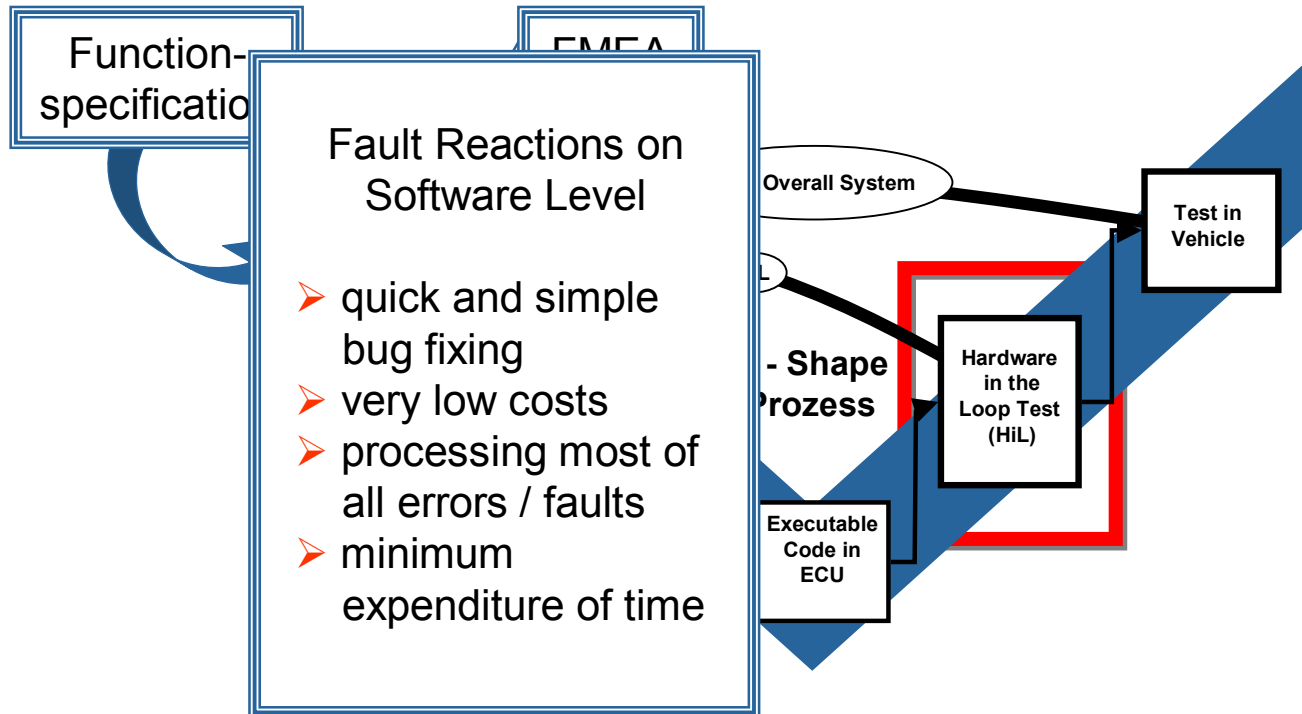

# Metamorphosis of the conventional V-Shape Process

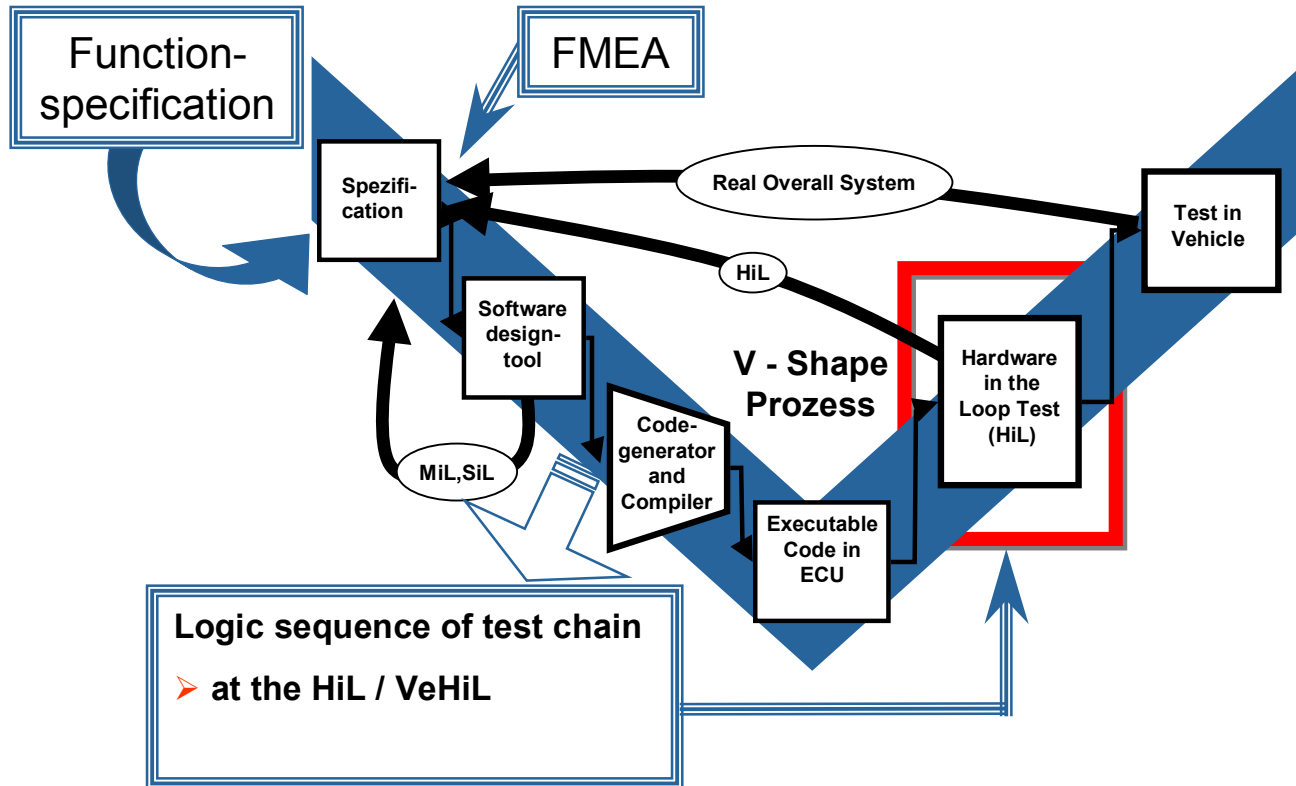

# Metamorphosis of the conventional V-Shape Process

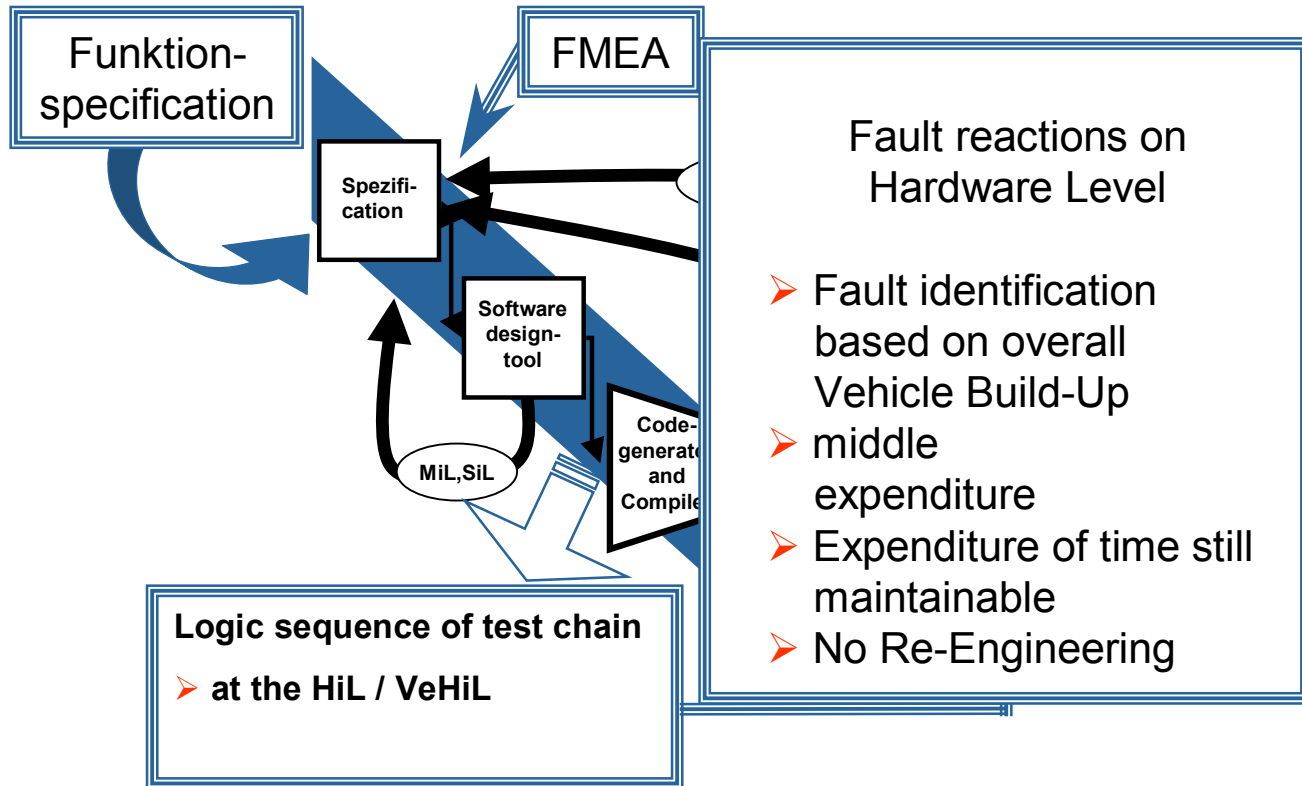

# Metamorphosis of the conventional V-Shape Process

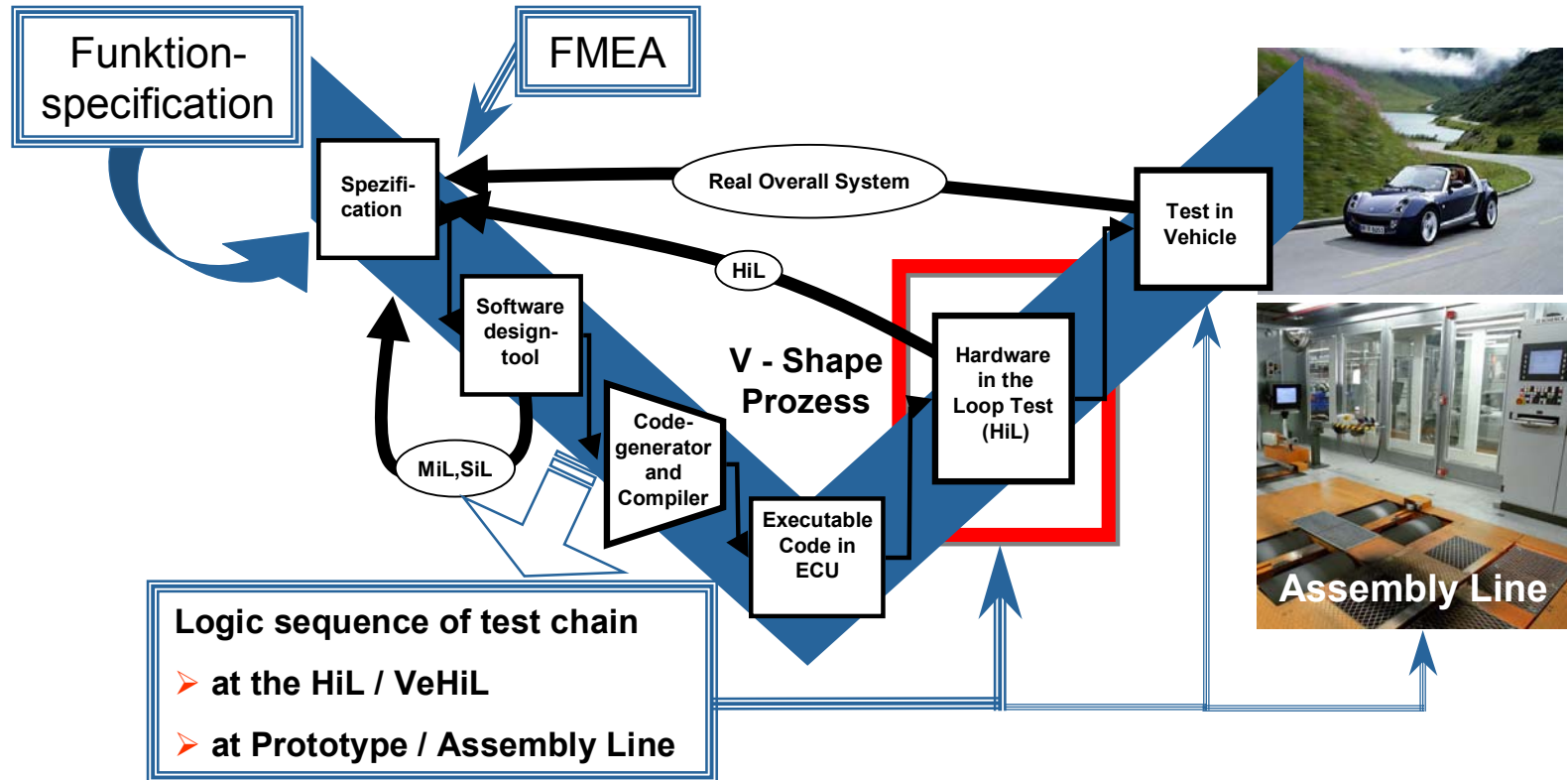

# Metamorphosis of the conventional V-Shape Process

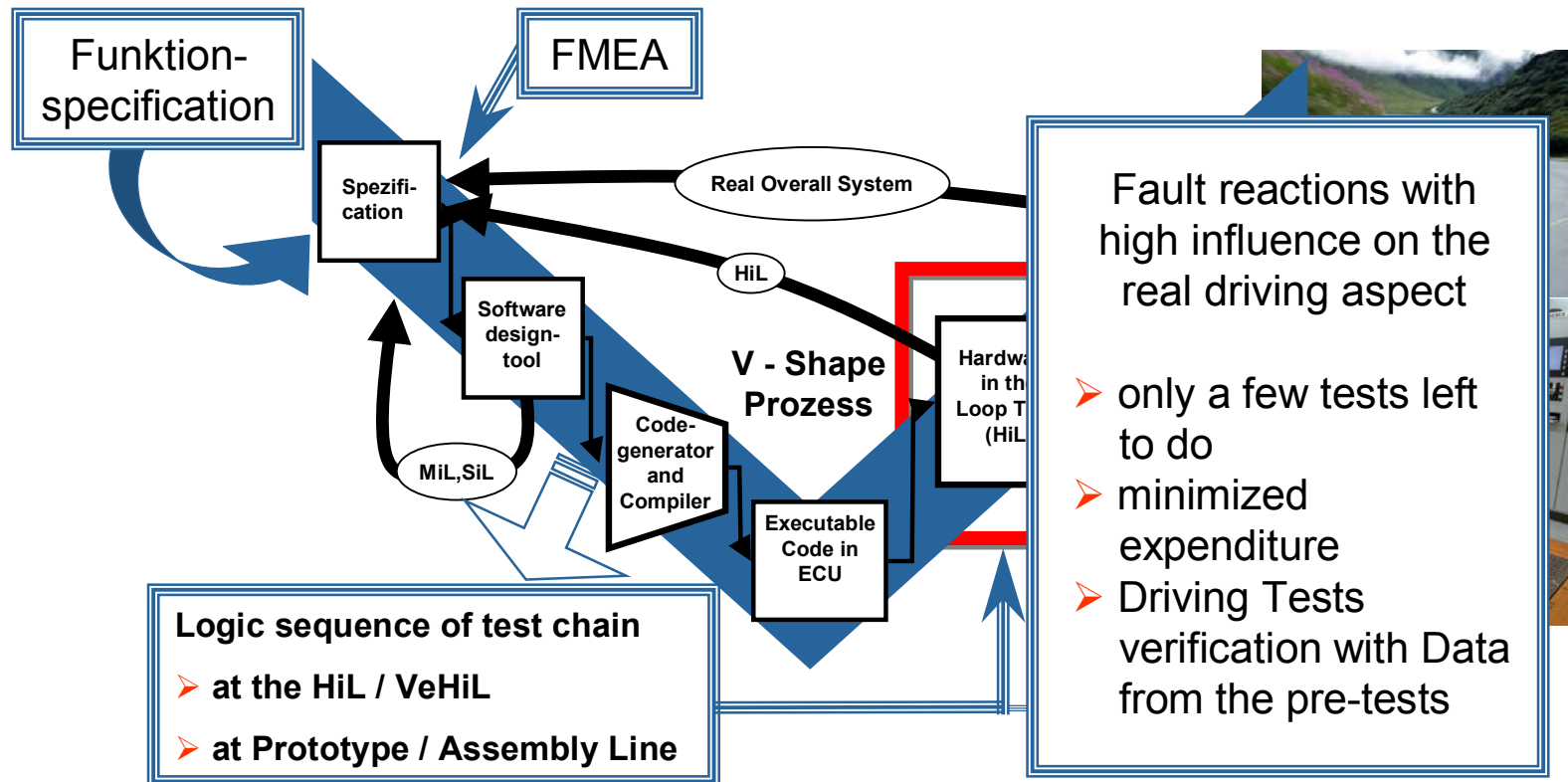

## Agenda

- **Why do we develop vehicle test procedures for the future... ?**
  - The EU Projects PEIT and SPARC
- **Metamorphosis of the conventional V - Shape Process (VDI 2206)**
  - Ascendancies on the development process of new vehicles and components
- **VeHiL - Vehicle (Hardware) in the Loop**
  - Configuration of the VeHiL – Function Tester (HGV / passenger cars)
  - Potentials of the VeHiL within the vehicle development process
  - Vantages of the VeHiL within the vehicle production (Line Assembly)

# Vehicle Hardware in the Loop – Function Tester (PEIT)

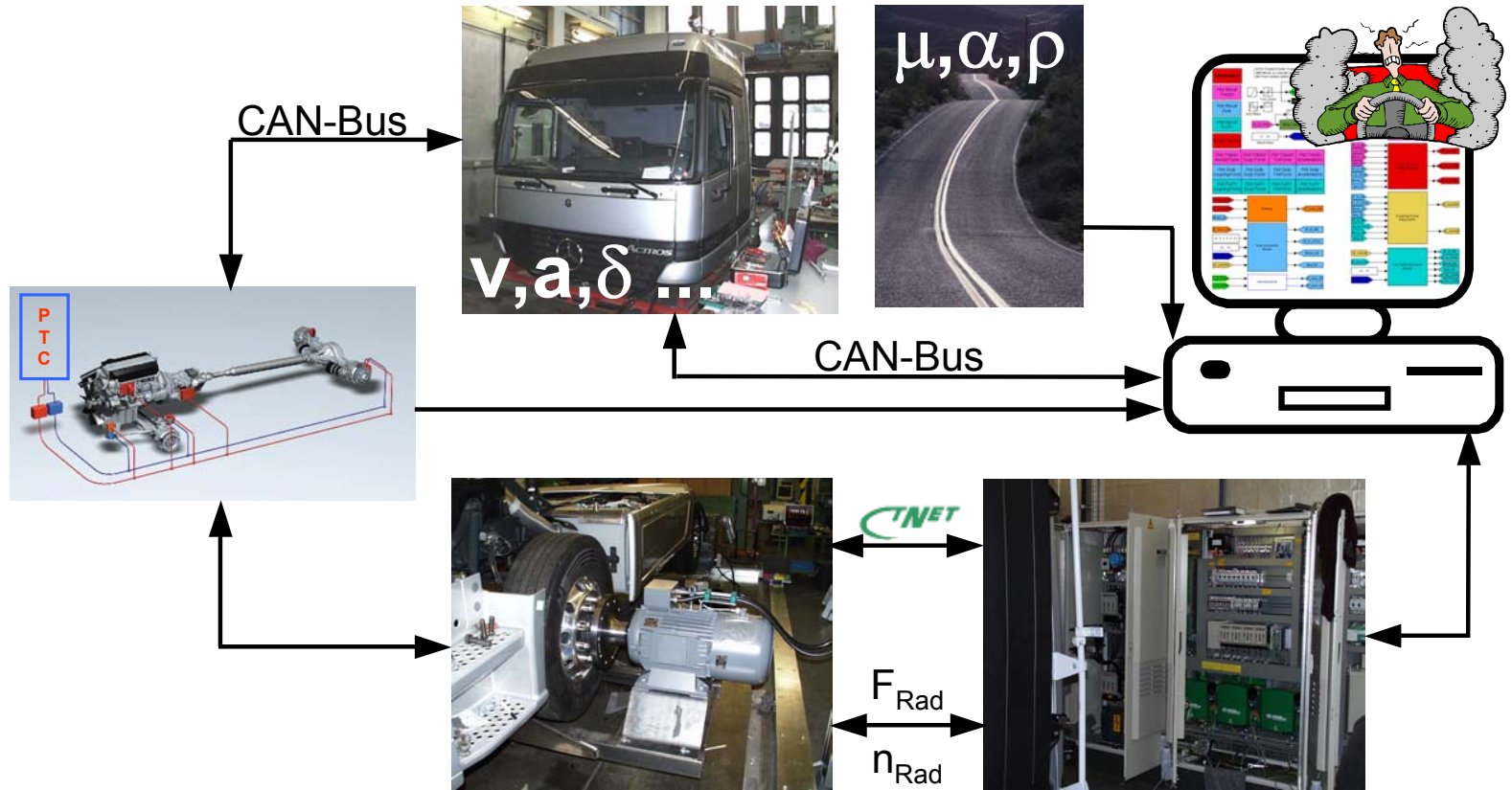

## Vehicle Hardware in the Loop – Function Tester (PEIT)

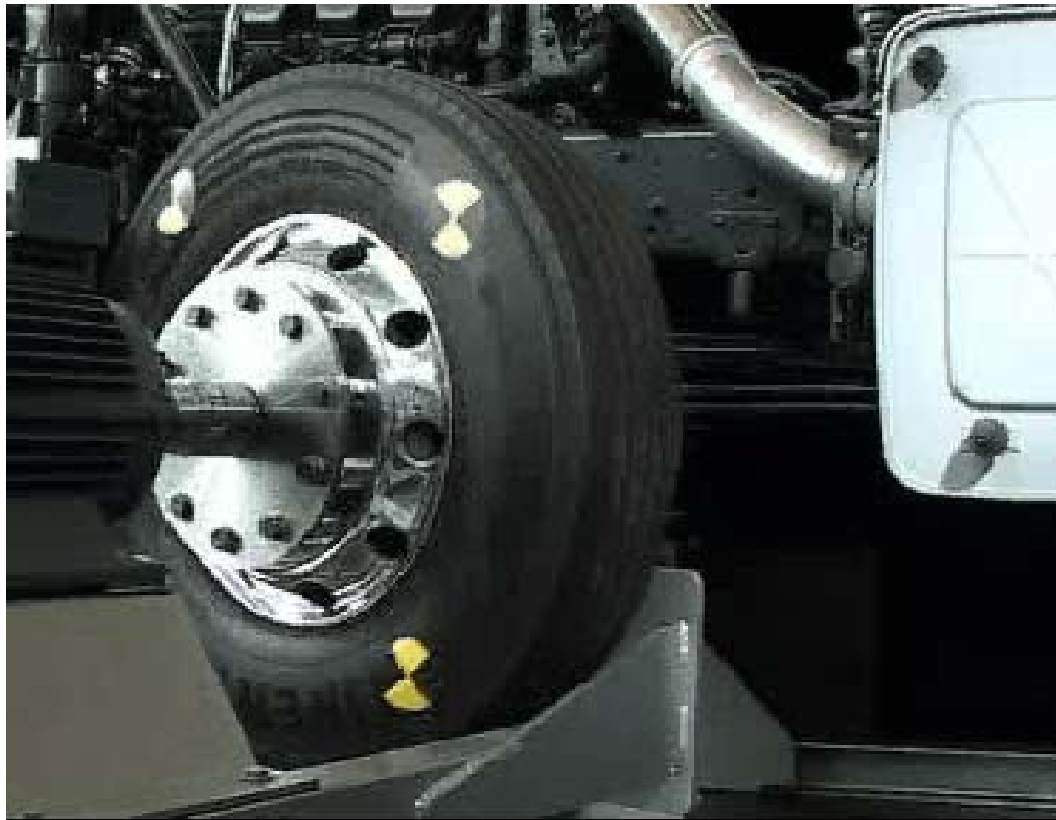

### Overview:

Device under Test is the  
entire Vehicle

Simulation of the Forces and  
Wheel Speeds for every single  
Wheel

Real dynamic Processes  
within the Power Train

Stimulation and Test of the  
PEIT with SCHENCK  
Technologies

Bulk of all tests can be done  
here or is already done

Vehicle (DuT) is steerable

# Vehicle Hardware in the Loop – Function Tester (PEIT)

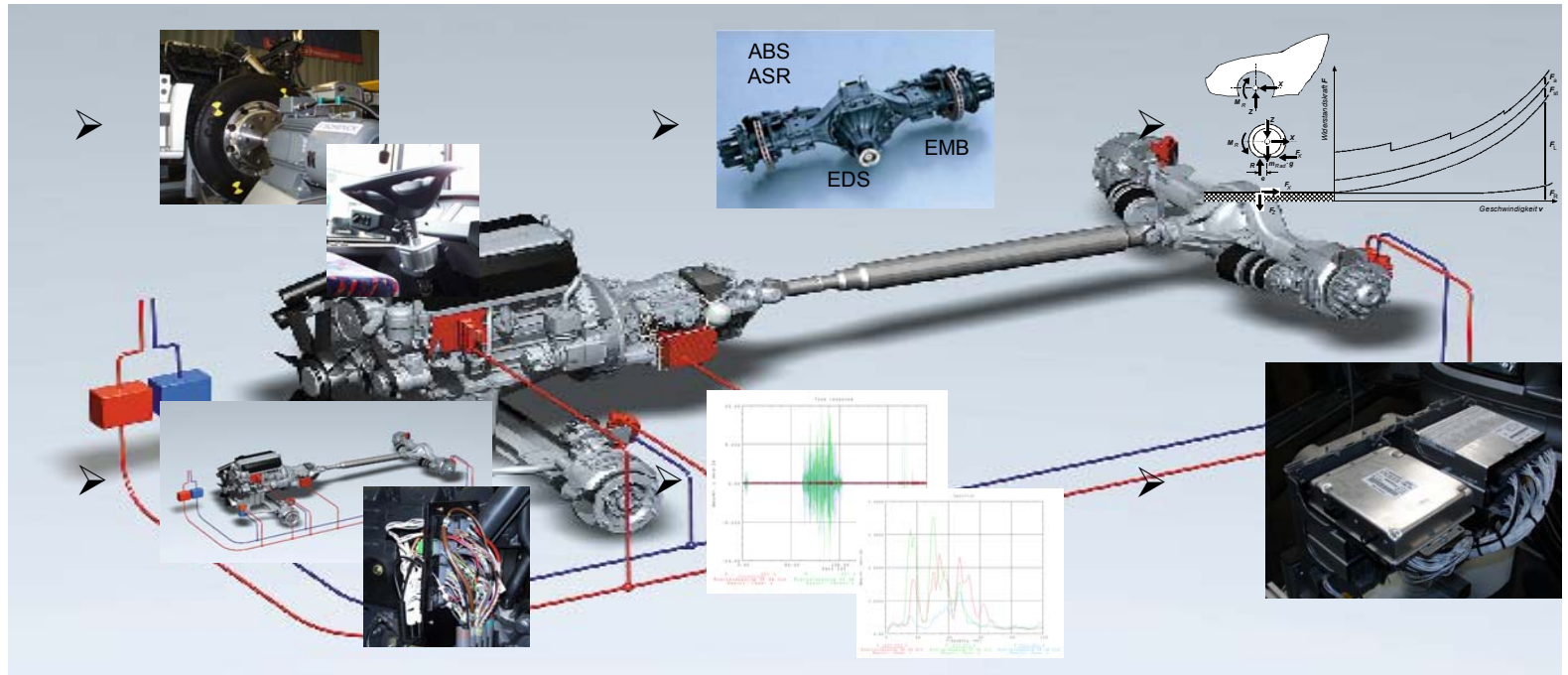

Ideal Requirements to test (Drive-by-Wire-) Functionalities  
 during the Development Process (before Prototype is released)

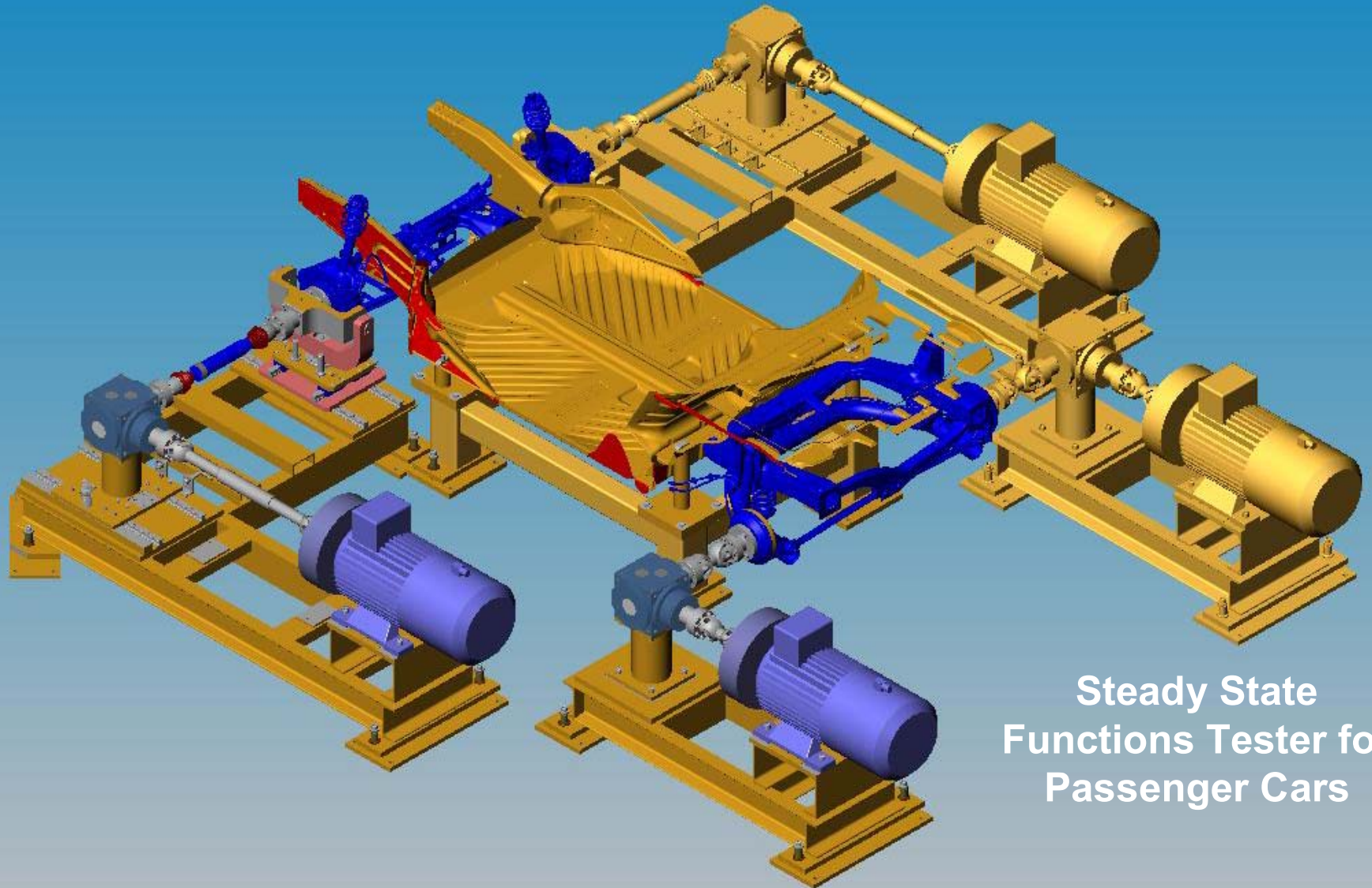

## Steady State Functions Tester for Passenger Cars

## Stress Unit for the steerable Vehicle Axle

CV – Drive Shaft

Displaceable Drive Shaft

Electro Motor

Adaptation to Brake Disc

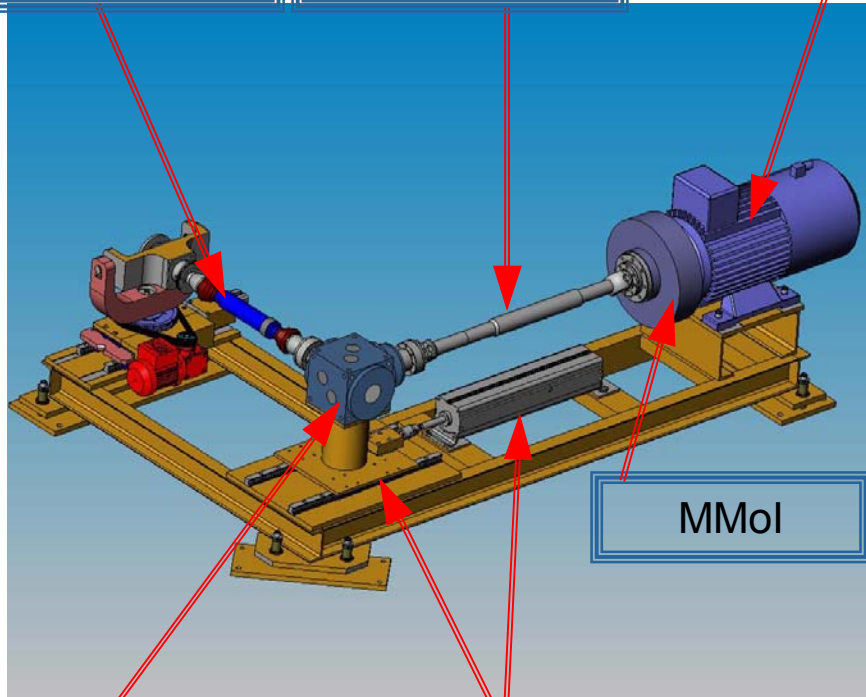

MMoI

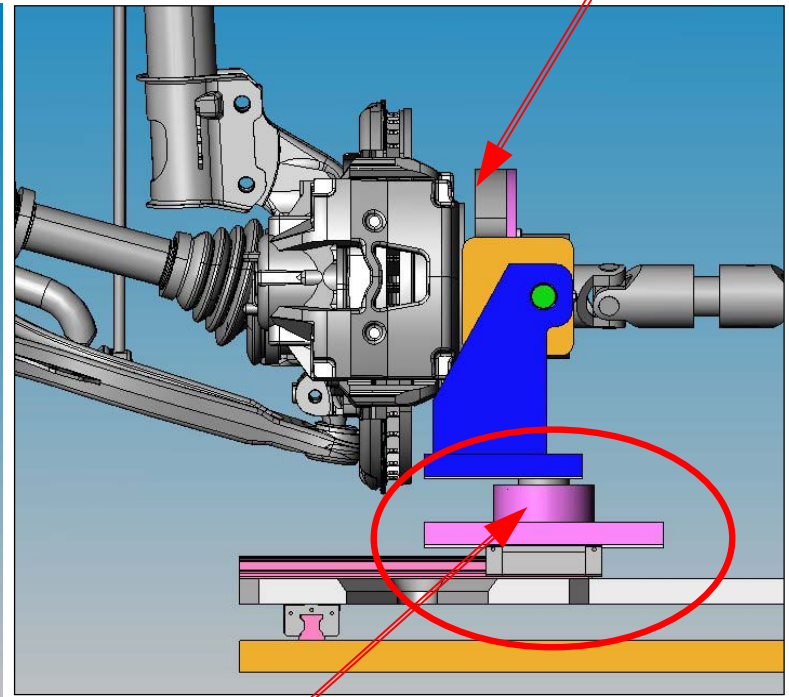

Angular Gear ( $i=1:2$ )

Displacement Unit

Steerable Support

**Thank you very much  
for your attention**

**J. Schenk**