

## De-central Data Acquisition - Trend or Innovative Approach?

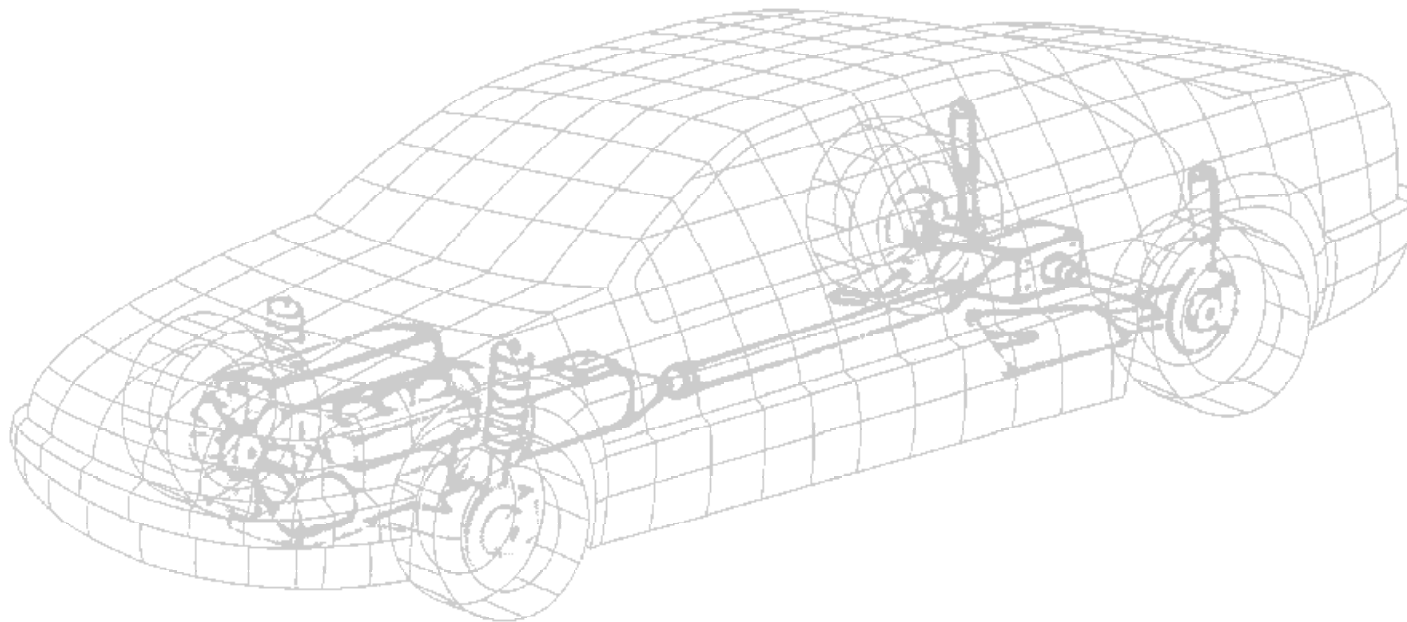

**Werner Streich**  
Schaeffler Automotive – AFT US Office

Ever more complex vehicle systems have resulted in the number of measurement points being doubled in the last few years!

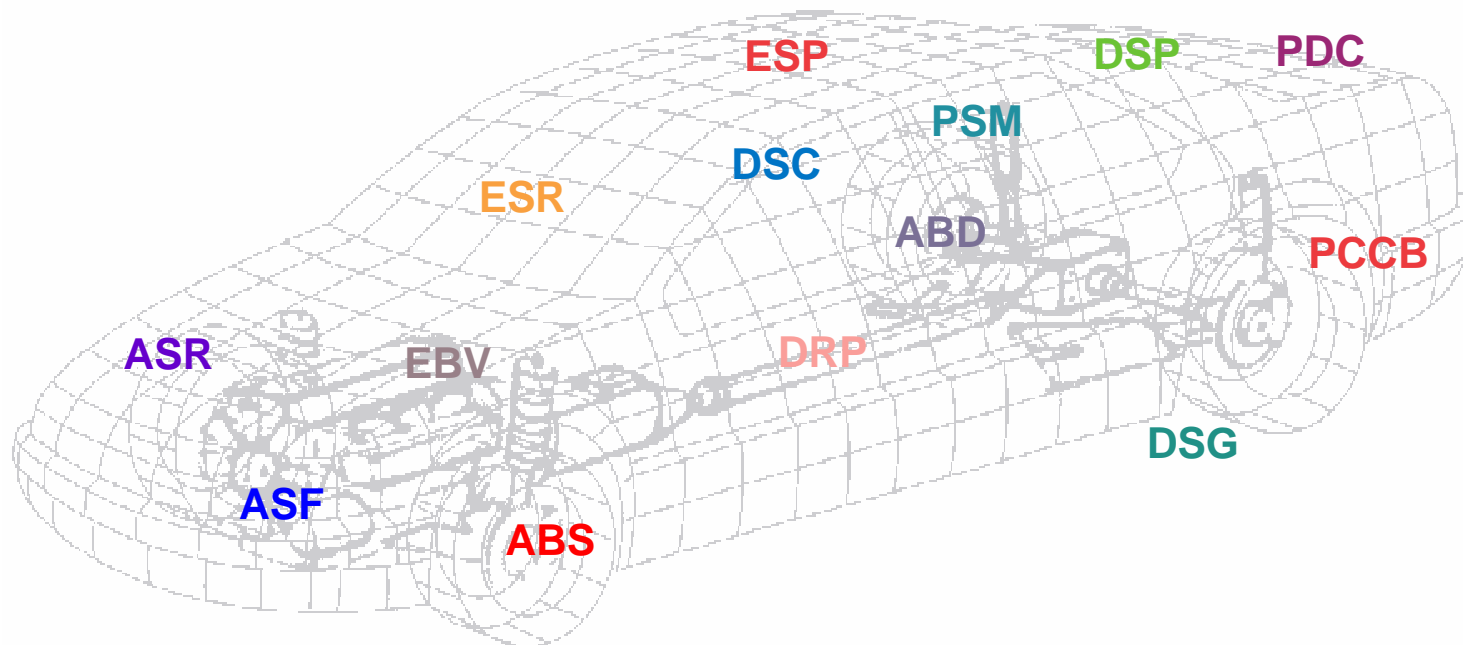

the job



**Fleet Test**

**Climate Test**

**ECU System Verification**

**Vehicle Network**

**Fatigue and Durability Test**

the job

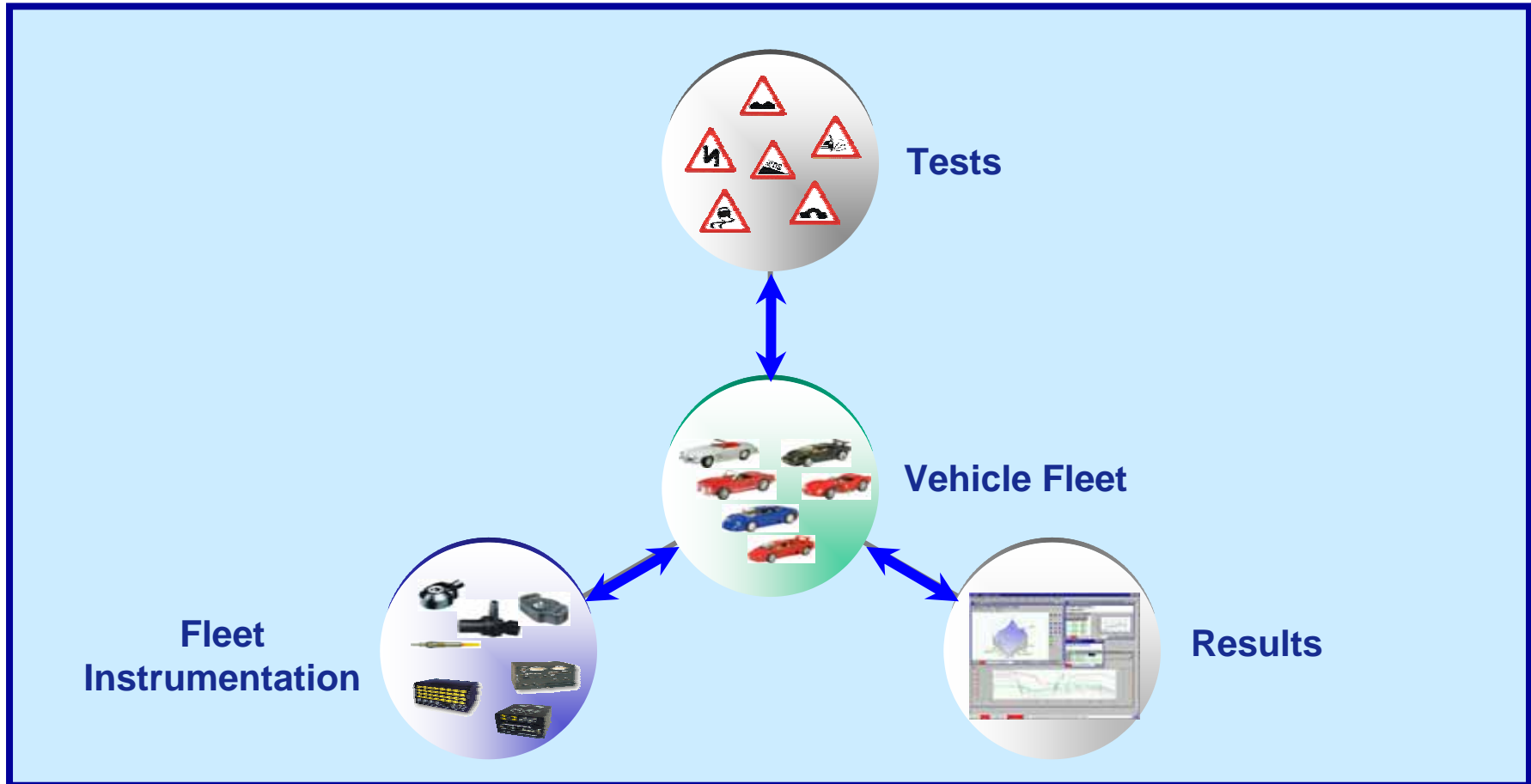



the job

the cost

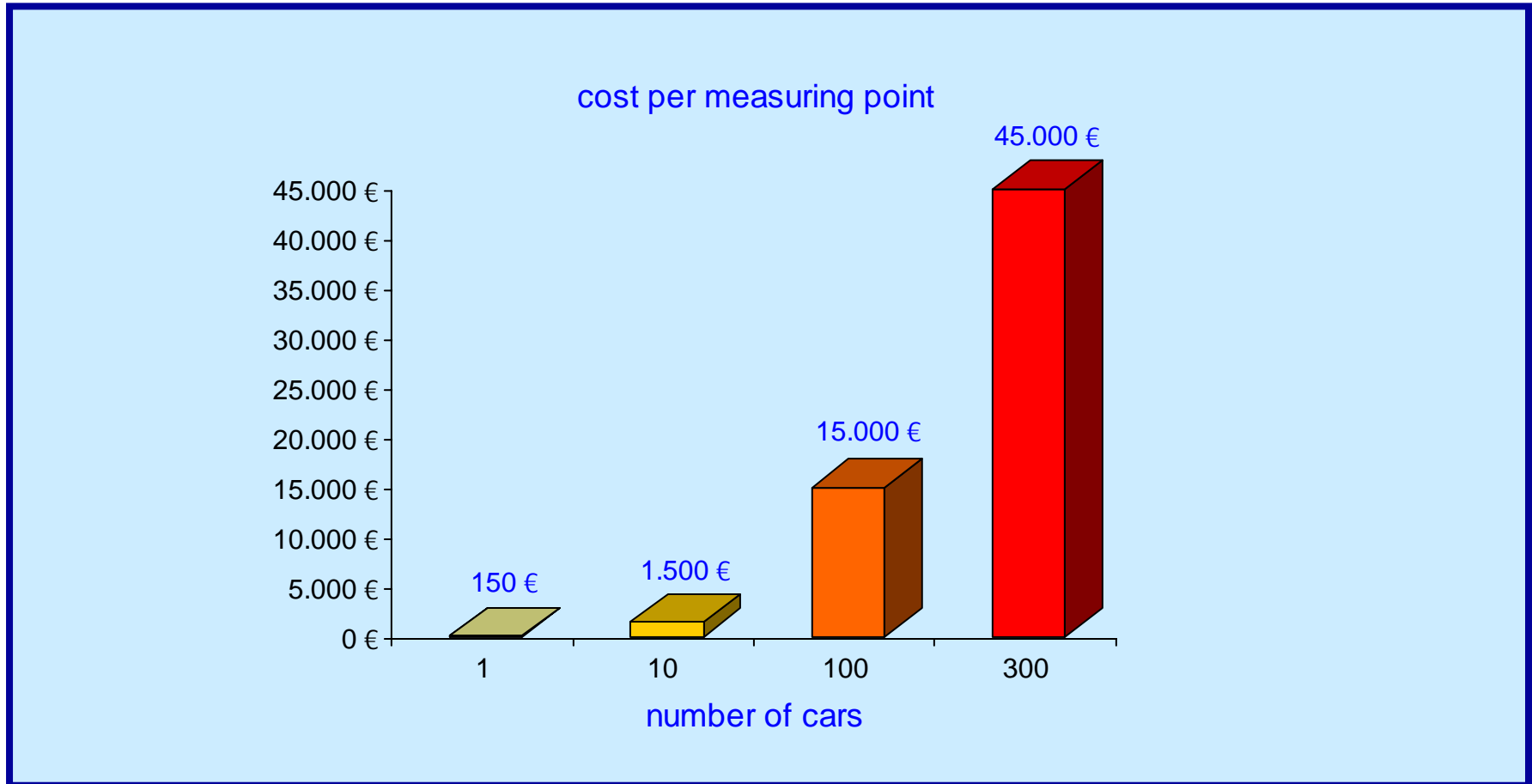



the job

the cost

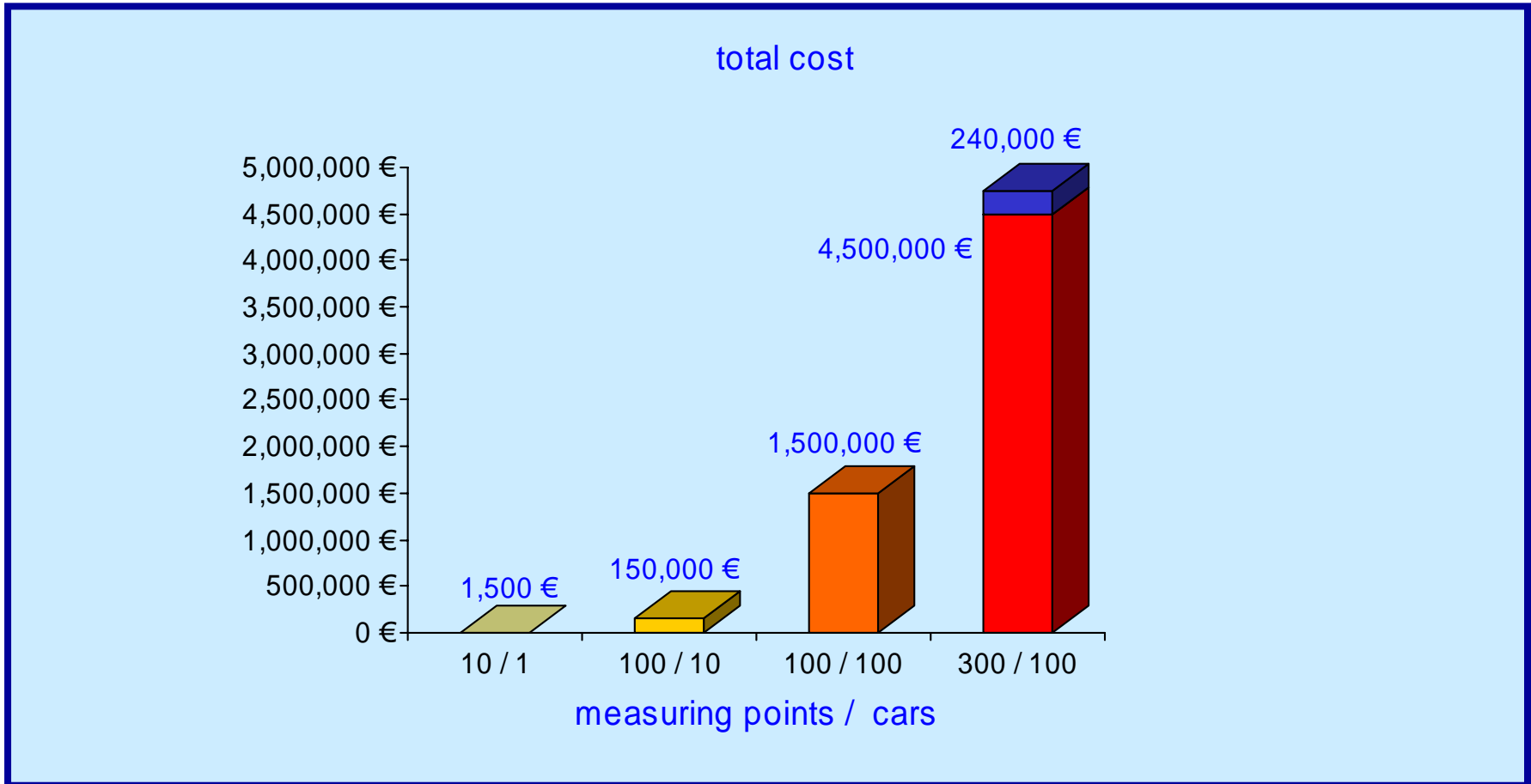



the job

the cost

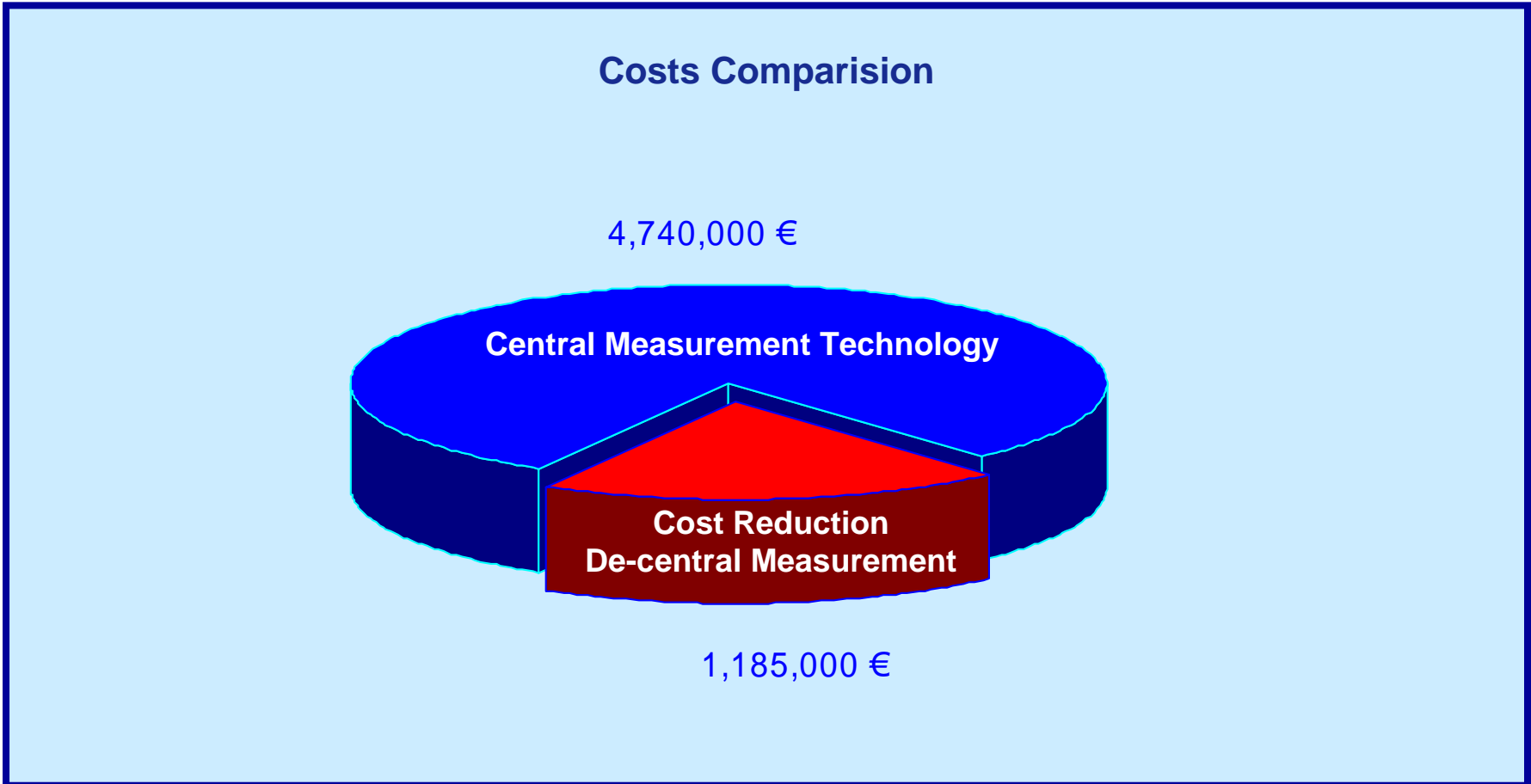

the job

the cost

the problem

- shorter processing times
- more complex system
- more sensors
- more measurement points
- more cabling
- limited installation space

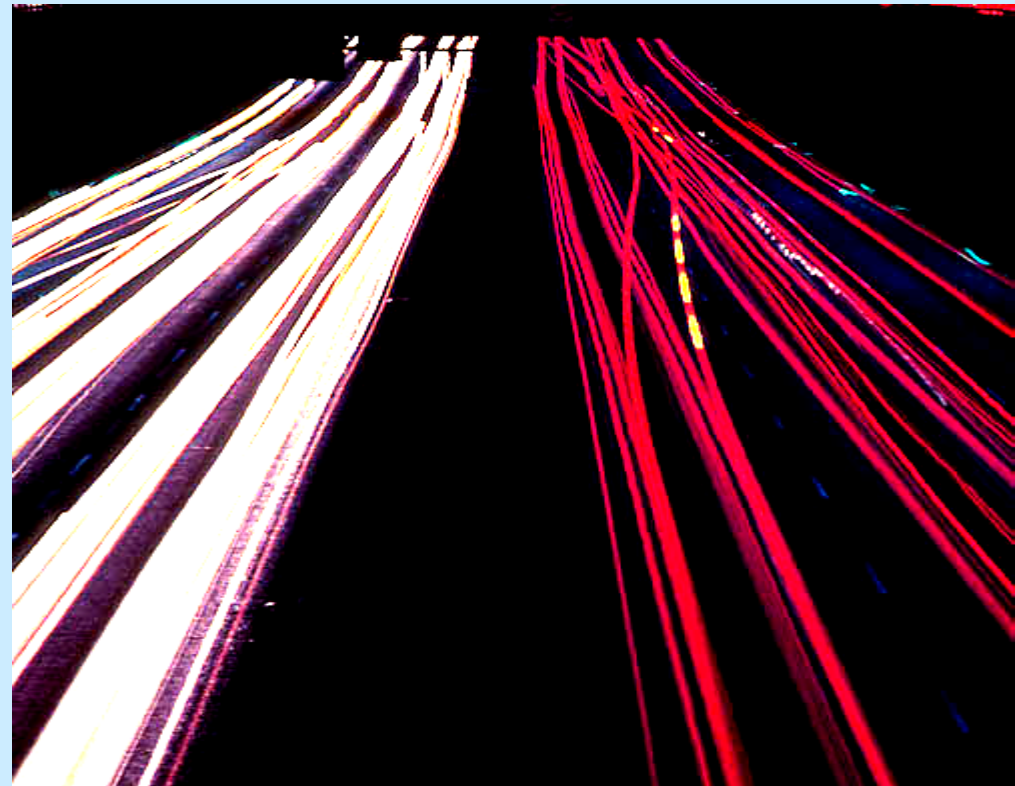

the job

the cost

the problem

- more measurement points
- more cabling



the job

the cost

the problem

➤ limited installation space



home

back





the job

the cost

the problem

the innovation

Size  Performance 



the job

the cost

the problem

the innovation

Which preconditions must a decentral measurement system fulfill, in order to provide a fully multi-functional system?

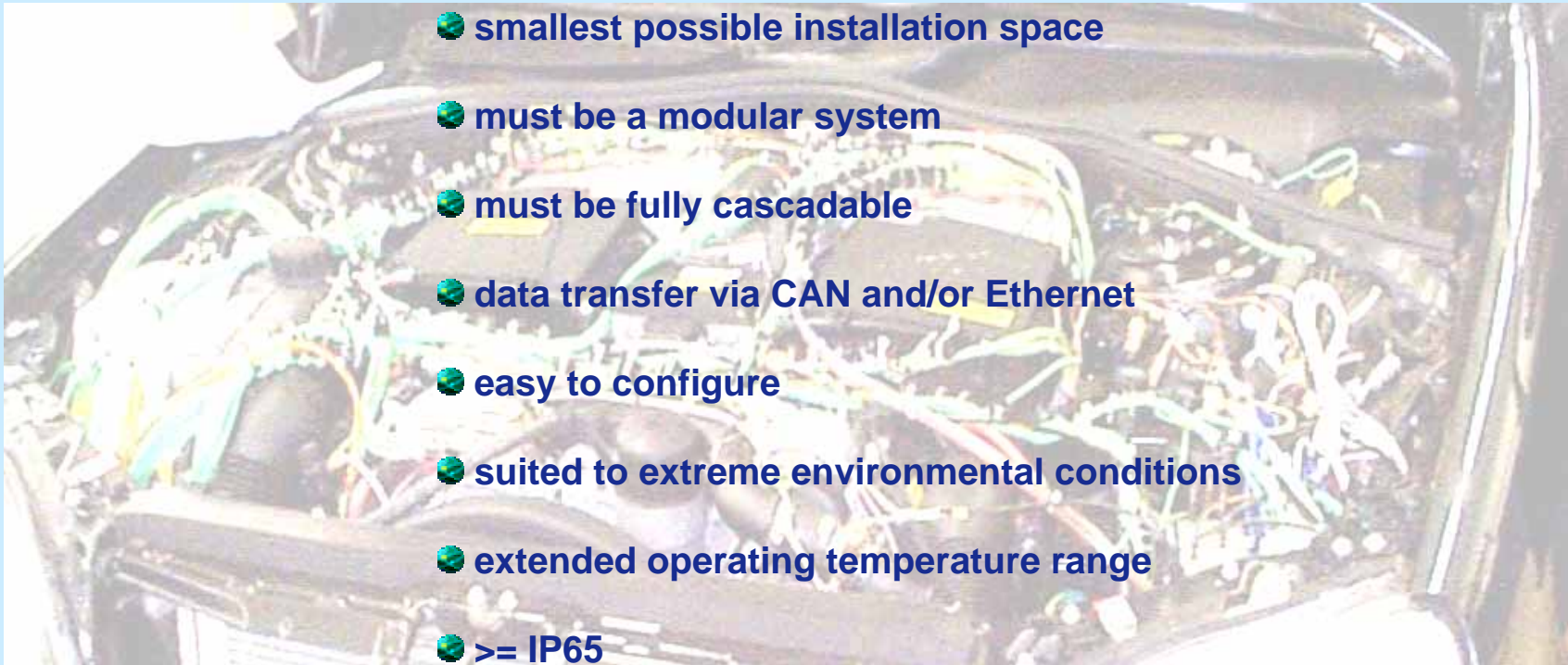

home

back

