



# Cost Considerations of Engine Test Facilities

Presented By:  
David R. Bartels  
Principal  
ACS





## Cost Considerations of New Engine Test Facilities



**ACS**  
Design · Construction · Integration



# Agenda

- Identifying Major Cost Components of Engine Test Facilities
  - Facility
  - Test
  
- Achieving Cost Effectiveness
  - Facility Considerations
  - Test Considerations
  - Project Delivery Options





## The Critical Environment Is No Longer Confined to the Cylinder

### Examples:

- Impact of Intake Air and Fuel Conditions On Performance / Emissions
- Chemical Reactions Occurring Outside the Engine (After Treatment)
- Advanced Power Train Systems / Hybrids
- NVH Considerations for Article Under Test and Equipment

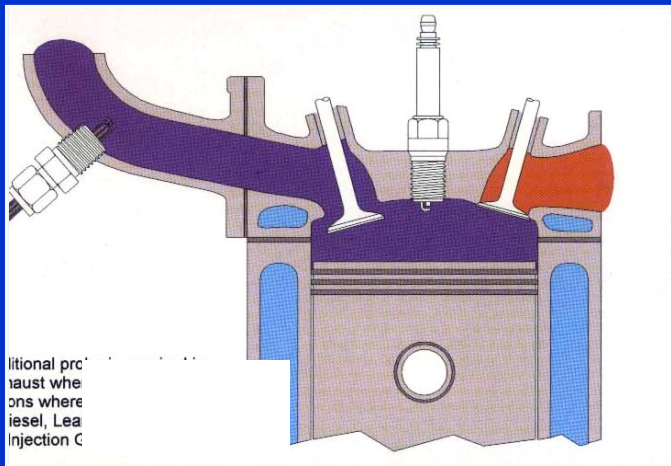

WAS

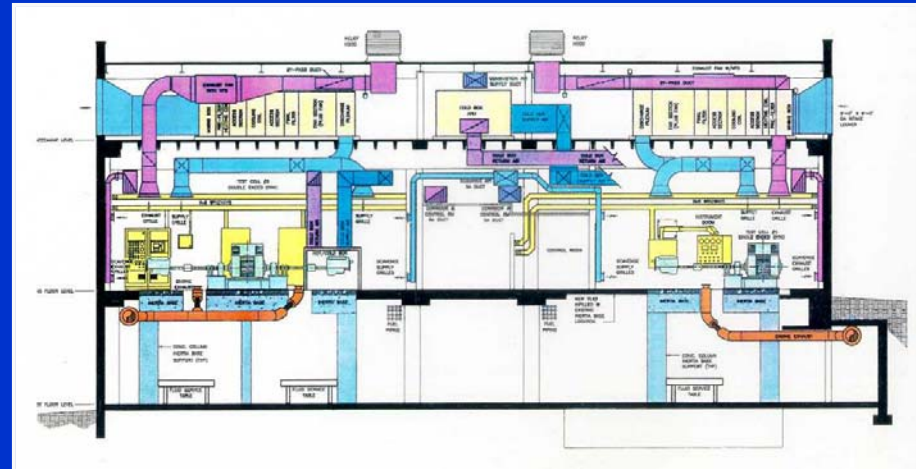

IS



# Cost Considerations of New Engine Test Facilities



**ACS**  
Design · Construction · Integration



## Elements of a Project Budget

### ➤ Building Core & Shell

- Foundation
- Superstructure
- Roofing
- Exterior Wall
- Interior Partitions
- Doors & Frames
- Interior Finishes
- Material Handling
- Plumbing
- Fire Protection
- HVAC
- Electrical

### ➤ Interior Development

- Interior Architecture Fit Up
- Plumbing Fit Up
- Fire Protection Fit Up
- HVAC Fit Up
- Electrical Fit Up

### ➤ Site

- Earthwork
- Roads
- Utilities
- Landscaping

### ➤ Construction Management

- Reimbursables
- Fees

### ➤ Project Contingency

- Design
- Construction
- Owner

### ➤ Design/Engineering Costs

- Architecture
- Structural
- Mechanical / Electrical
- Specialty Consultants
- Soils

### ➤ Furniture

- New
- Relocated / Restored

### ➤ Other Costs

- Permits
- Bonding
- Telephone / Data
- Security
- Mock Up (If Required)
- Site Logistics (Constraints)

### ➤ Equipment

- Facility
- Test

### ➤ Integration Costs

- Facility and Equip Design
- Equipment Start Up
- Cx & Validation



## Project Components – Facility Costs

- General Construction
- Permitting
- Demolition
- Site Work
- Plumbing
- Fire Protection
- General Electrical
- General HVAC





## Cost Considerations of New Engine Test Facilities



**ACS**  
Design · Construction · Integration



# Project Components – Facility Costs

- Fuel Storage / Distribution
- Bottle Gas Storage / Distribution
- Test Article Storage / Distribution
- Specialty Power and Grounding
- Facility Systems Control





## Project Components – Facility Costs

- Hot Water
- Chilled Water
- Tower Water
- Process Water
- DI Water
- Cell Ventilation Air
- Combustion Air
- Dilution Air
- Scavenge Air
- Instrument Air



*Facility Cost Magnitudes Often Overlooked/Underestimated*



# Project Components – Test

- Environmental (Hot / Cold) Rooms
- NVH Enclosures / Doors / Windows
- Test Bed Vibration Isolation
- CVS Systems
- Gas Detection Systems

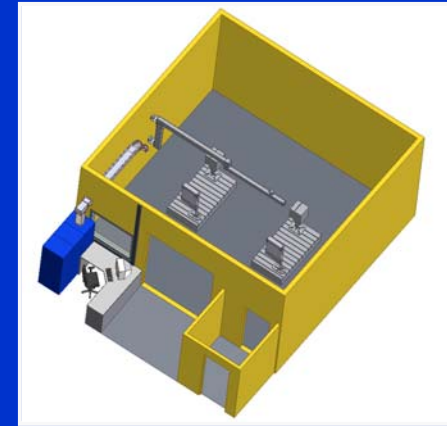

*Utilize Test Equipment Suppliers as Consultants*



# Project Components – Test

- Dynamometer Systems
- Data Acquisition and Control
- Test Fixtures
- Driveline
- Engine Fluid Conditioning
- Emissions Measurement
- Combustion Analysis

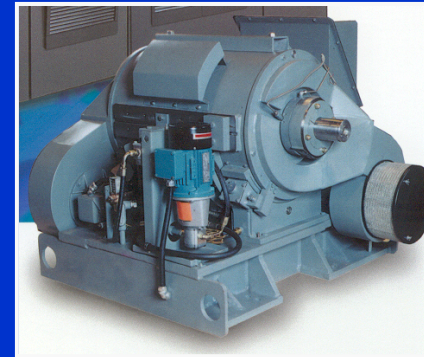

*Market Forces Present Cost Savings Opportunities*



## Project Components – Test

- Transducers / Thermocouples
- Specialty Instrumentation
- Test Article Fluid Adaptors
- Harnessing, ECU / ECM
- Test Article Mounting
- Data Collection / Distribution / Post Processing

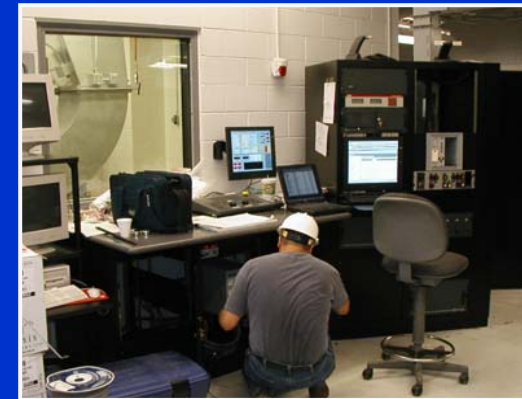

*Identify early owner / supplier responsibilities*



## System Selection Constraints

### ➤ Internal Constraints

- Capital Cost
- User & Maintenance Labor Cost
- Union Requirements
- Data Efficiency (“Data Glut” Avoidance)

### ➤ External Constraints

- Regulatory Requirements
  - US EPA, ISO, European Union, Japanese CCEPC
- Upstream Customer Requirements
  - Hardware Commonality, Seamless Data Transfer

### ➤ Resource Constraints

- In-House vs. Out-of-House Development & Support
  - Addition/Modification Control
  - Capital Cost vs. Overhead Cost
  - Services Response Timelines
  - Intellectual Property Ownership

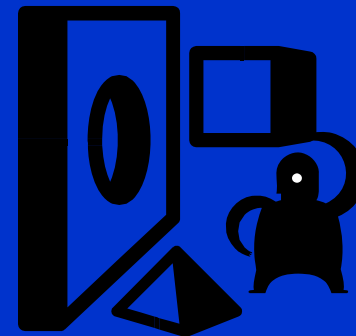



## Project Components – Indirect Costs

- Architectural / Engineering Services
- Construction Management Services
- Commissioning & Integration Services
- General Conditions

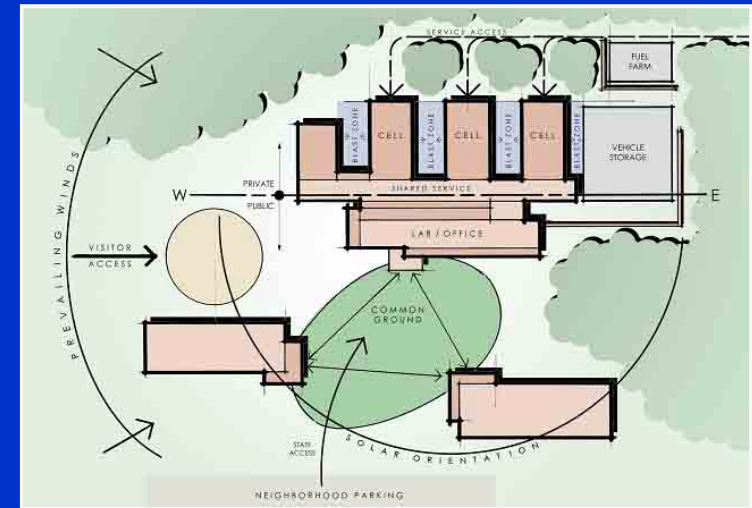

*Project Complexity drives Indirect Costs*



## Cost Considerations of New Engine Test Facilities



**ACS**  
Design · Construction · Integration



# Achieving Cost Effectiveness

- Project Understanding
- Value Engineering
- Project Delivery





# Cost Considerations of New Engine Test Facilities



**ACS**  
Design · Construction · Integration



## Understanding / Challenges / Expectations

### Understanding

- New Product Development
- Acute Shortage of Testing Capability
- Facility Support
- Occupancy Date
- Budget

*The Right Team  
Executing the  
Right Approach*

### Challenges

- Large Project Execution
- Active Campus
  - Ongoing Adjacent Research
- Accurate Conceptual Estimating
- Fixed Budget
- Schedule
- Keeping Team "On Track"

### Expectations

- Ensure Design Fits Budget
- Experienced Engine R&D Team
- Accurate Conceptual Estimating, Particularly MEP
- Cost Control / Schedule Control
- Cohesive and Focused Project Team
- Minimize Disruption to Ongoing Activities
- Accelerated Schedule without Premiums
- Best Value for Capital Investment



## Cost Considerations of New Engine Test Facilities



**ACS**  
Design · Construction · Integration



# Cost Effective Considerations

- Floor to Floor Elevations
  - Prove the Need for Every Foot
  - \$\$/SF of Shell Construction
  - Pipes, Conduits, Ducts
  
- Basements
  - Cost Effectiveness
  - Code Requirements
  - The Good and the Bad





## Cost Considerations of New Engine Test Facilities



**ACS**  
Design · Construction · Integration



# Cost Effective Considerations

- What is “Facility;” and What is “Test Equipment”
  - CVS Systems, Clean Rooms, Bottle Gas, Etc.
  - Vendor vs. Contractor
  - The Right Tool (Person) for the Job
  
- Central vs. Unitary Systems
  - \$ / CFM, \$ / GPM
  - Diversity Factors
  - Reliability / Downtime





## Cost Effective Considerations

- Conditioned Spaces
  - Workspace vs. Test Space
  
- Cell Layout
  - Ergonomics
  - Throughput
  
- Structural
  - Wall Materials
  - Inertia Mass vs. Air Bags

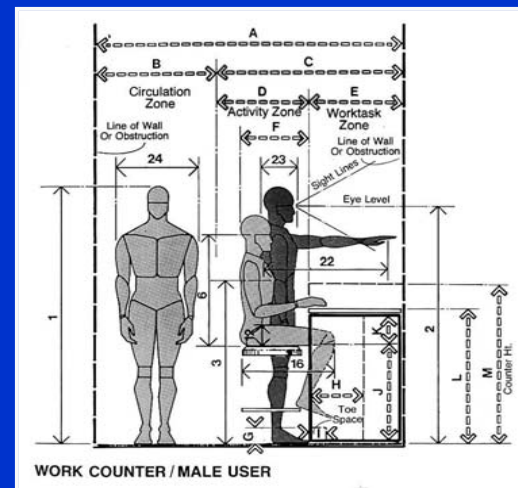



## Cost Considerations of New Engine Test Facilities



**ACS**  
Design · Construction · Integration



# Cost Effective Considerations

- Data Acquisition
  - The Ever Changing Market
  - Commercial Products vs. Home Grown
  
- Dynamometers
  - AC Machines in Traditional EC Applications
  - Electrical Power vs. Cooling Water
  
- Emissions Measurement
  - Analysis of Targeted Variables
  - “The Needle in the Haystack”





## Facility Integration Encompasses the Entire Project Cycle

### Planning

- Program Verification
- Site Evaluation
- Compliance
- Budget/Schedule

### Facilities

- Master Planning
- Arch/Struct
- Mech/Elect/Piping
- Data Networks
- Fire Protection

### Integration

### Equipment

- Dynamometers
- Data Acquisition
- Emissions & Span Gases
- Fuel & Combustion Air
- Cold Rooms

### Construction

- Prototype/Mockup
- Contracting
- Cost Containment

### Commissioning

Begins Early in the Planning Process  
Focuses on the Process  
Ensures Life Safety  
Marries Facility and Process  
Drives Commissioning  
Documents End Product  
Delivers Functionality



# Cost Considerations of New Engine Test Facilities



**ACS**  
Design · Construction · Integration



## Cost Effective Considerations – Project Delivery Methods

### Traditional: Design - Bid - Building Delivery

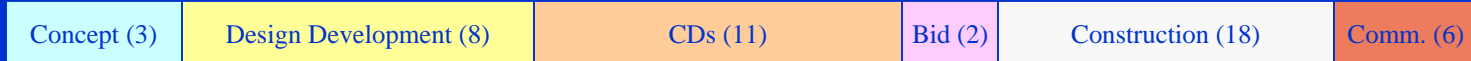

### Fast Track Delivery

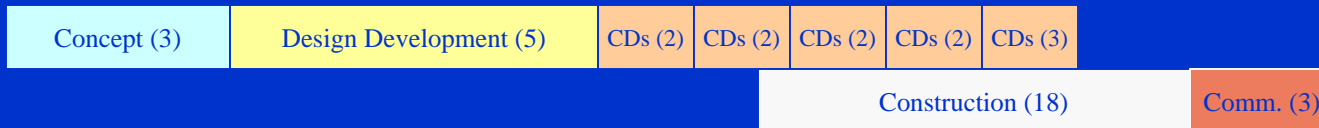

### Integrated Delivery

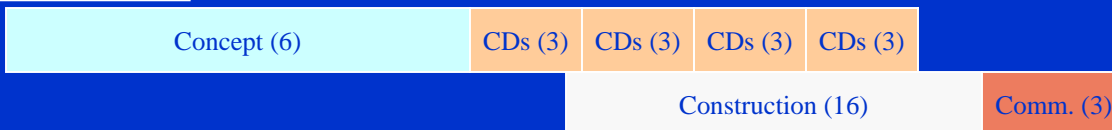



# Cost Effective Considerations – Direct Procurement vs. General Contracting

- Competitively Bid
- Multiple Suppliers
- Direct Contracting
  - Trades
  - Equipment



*Delivers Value by Removing Multi-Tier Mark-Ups*



# Cost Considerations of New Engine Test Facilities



**ACS**  
Design · Construction · Integration



## Traditional Procurement (Mechanical Package)

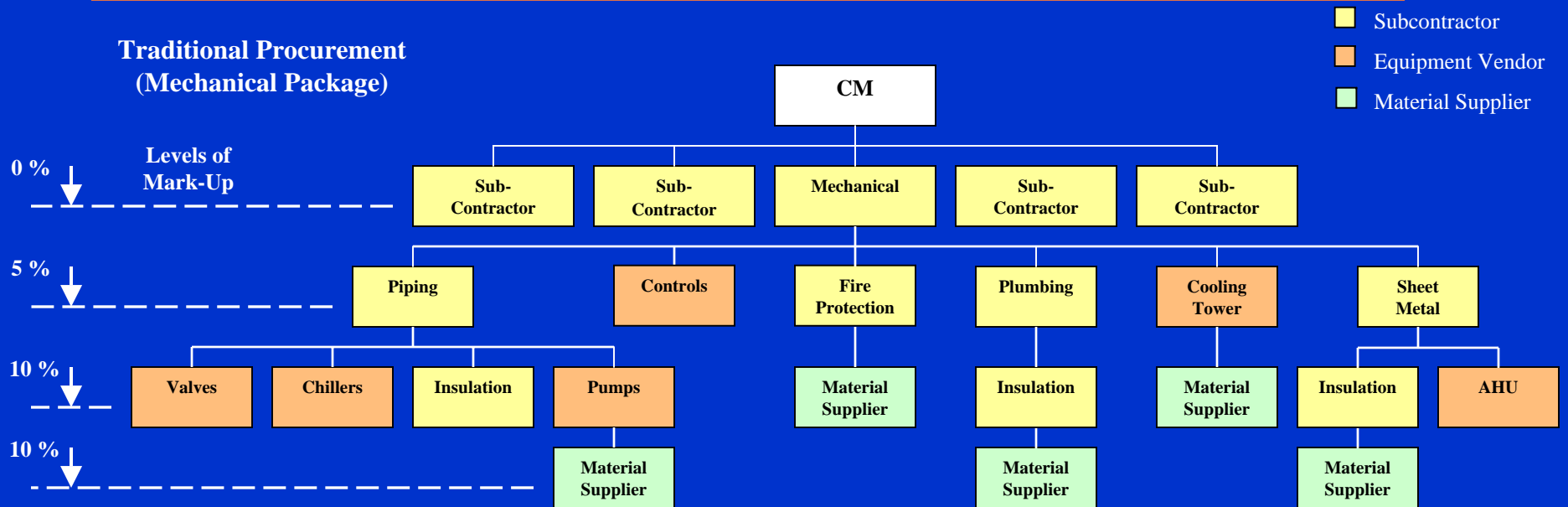

## Integrated Approach (Mechanical Package)

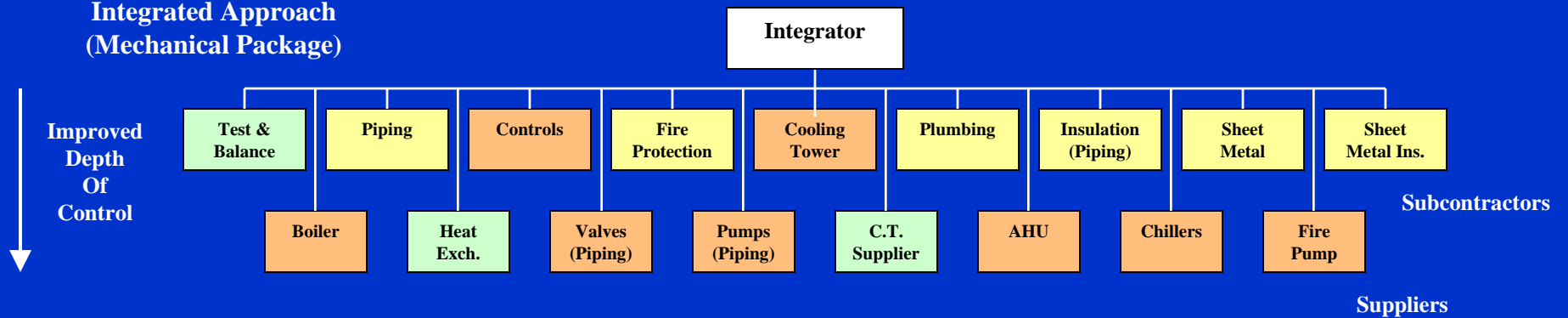



# Cost Effective Considerations – Integration and Commissioning Services

- Starts at Design Stage
- Integrates Design, Procurement, Construction, and Equipment
- Develops and Implements Procedures to Manage
  - Document Control
  - Quality Control
  - Punch List Execution
  - System Completion Focus
  - Turn Over Package Development
  - Start Up and Commissioning Plans
  - System Certification Requirements
- Documentation

*Ensures Systems are Fully Functional at Occupancy*



## Cost Considerations of New Engine Test Facilities



**ACS**  
Design · Construction · Integration



## Summary

- Facility Choices Impact Test Data / Facility Costs Equal to or Greater Than Test Systems
- Facility and Equipment Options Present Many Functional / Cost Savings Alternatives
- Project Delivery Methods Can Have Greatest Impact on Project Success.



*Engage Experienced Team for Test Facility Projects*