

Engineered Measurement Systems, Inc.
Professional Experts in Strain Gages and Torque / Horsepower Measurement

2006 North American Test Expo Open Forum

EMS Next Generation,
Coastdown & Drive,
Wheel Torque-Meter

OVERVIEW OF MEASUREMENT SYSTEM

Accurate Measurement of:

- Friction & Drive, Wheel Torques.
- During Acceleration, Steady-State, Deceleration and Coastdown Modes.

Accomplished with the Use of:

- Special High Range / Low Range, *Next Generation* Coastdown & Drive, Wheel Torque-Meters, on an Automotive Chassis that has been “Broken-In” (i.e. vehicle’s friction losses have been stabilized).

OVERVIEW OF MEASUREMENT SYSTEM

- Test Track Runs are Accompanied with a Wind Anemometer and Vehicle Velocity Sensor.
- Roll Dynamometer Runs are Accompanied with Wheel Speed Sensors.
- Temperature Measurements of Ambient and Vehicle Components, at the Test Track & on the Dyno.

MEASUREMENT SYSTEM GOALS

- Measurement of the *Actual* “Road Load” Forces Acting on the Vehicle at the Test Track & on the Roll Dynamometer.

The Separation of *Horsepower Losses* into:

- *Aerodynamic Drag*
- *Tire Rolling Resistance*
- *Lump Sum Chassis Friction*
- *Certain Components of Chassis Friction*

Special Torque-Meter Requirements:

- Very High Torsional Overload is Required.
- Minimum Errors Due to Temperature and Temperature Gradient Conditions.
- Negligible Errors from Very High Radial Loads.
- Negligible Errors from Bending Moments.
- Excellent Low Range Repeatability.

Other Torque-Meter Features:

- State-of-the-Art/Science of a Strain Gage Based Measurement System.
- Good Fatigue Life.
- Rotary Transformer Power & Signal Electromagnetic Coupling System.
- Contains **NO** Rotating Electronics.
- $\pm 250,000$ Counts of Stable Resolution.
(i.e. $\pm 25,000$ in-lbs with 0.1 in-lb Resolution)

Typical Types of Application Tests:

SAE Recommended Practices:

- J1263
- J2263 in Conjunction with J2264.

Test Track & Chassis Rolls Dynamometer:

- Series of Coastdowns.
- EPA Certification Type, Highway Drives.
- European Type, Steady-State Drive Tests.

Definitions of Terminology

“Road Load”:

- *Generic*: Forces that Impede Vehicle Motion.
- *Common Thought*: The Amount of Force Needed to Propel a Vehicle Forward.

“ETW” (Equivalent Test Weight):

- Several Interpretations & Misuses.
- Formal Definition & Discussion is Being Written for the J2264 Appendix.

Basic Coastdown Test

- Vehicle is Accelerated to ~75 mi/hr (120 km/hr).
- Transmission is Disengaged to a “Neutral” Position.
- Vehicles Coasts to a Stop.
- Speed-Time Data is Recorded from 70 mi/hr (113 km/hr) to a Stop.
- “Road Load” is Determined as a Function of Velocity.

Model of a Basic Coastdown Test

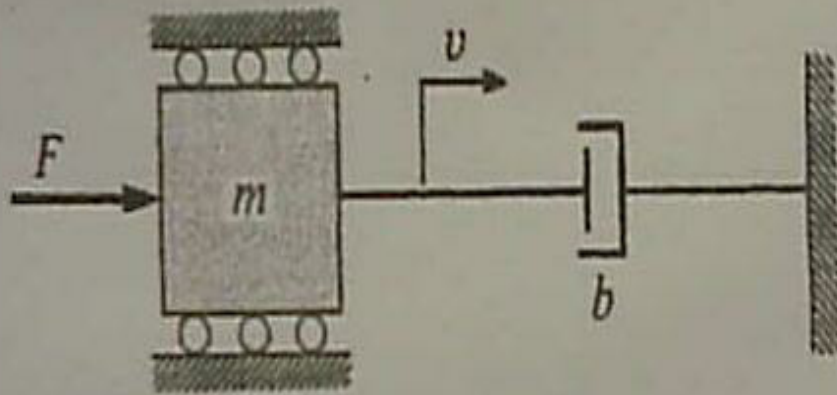

Fig.1 Mechanical Model of a Coastdown Test

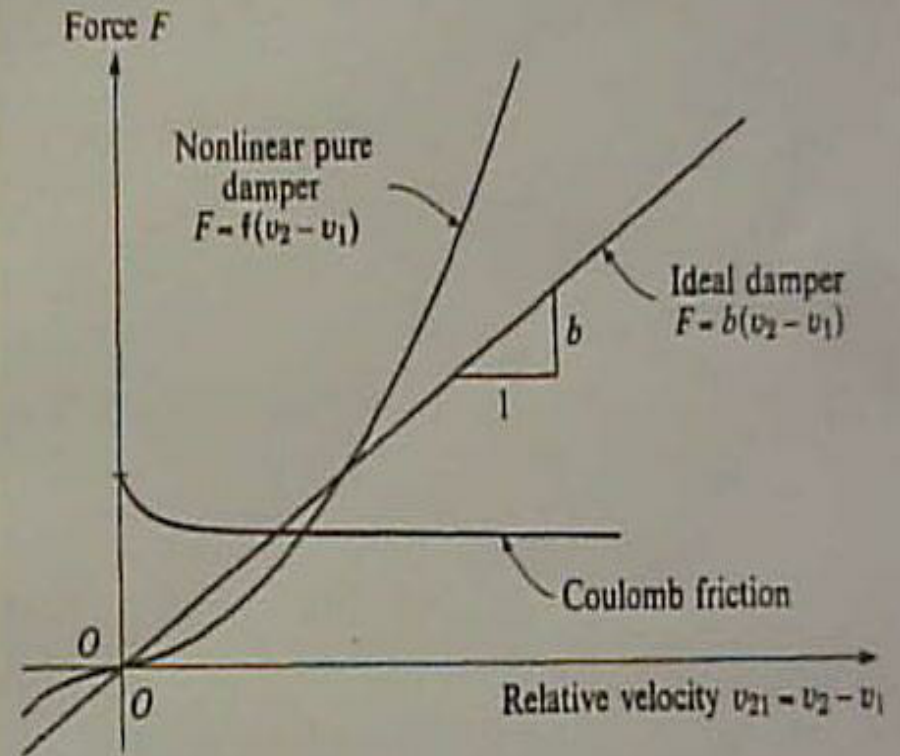

Fig. 2 "D"-Type Energy Dissipation

Background to Coastdown Testing

- The EPA Requires the Use of Chassis Roll Dynamometers for Vehicle “Emissions” & “Fuel Economy” Testing/Certification.
- The Dynamometer must Simulate the Dynamic & Steady State Loads on the Vehicle from a Representative Drive Cycle.
- Coastdown Testing has been Accepted by the EPA as a Means of Determining a Power Absorber Setting Which Simulates the “Road Load” of the Vehicle.

Forces Acting on a Coasting Vehicle

Aerodynamic Forces:

- Drag
- Lift
- Side Forces

Tire Rolling Resistance:

- Tire Rolling Deformation

Chassis Drag:

- Drive Train Components
- Brakes
- Seals

SAE International Procedure J1263

“Road Load Measurement & Dynamometer Simulation Using Coastdown Techniques”

- Antiquated Procedure, but Still Used by Some.
- Replaced by J2263 (Test Track) & J2264 (Roll Dyno).

Basic Drawbacks:

- Very Low/No Wind Conditions.
- 2-Term “Road Load” Coefficients.
- Written for “Old Style” Type Roll Dynamometers.

SAE International Procedure J2263

“Road Load Measurement Using Onboard Anemometry and Coastdown Techniques”

- Improved J1263 Test Track Procedure.
- Good Results with Low to Moderate Wind Conditions.
- 3-Term “Road Load” Coefficients.
- Used in Conjunction with SAE Procedure J2264 (Dyno)

SAE International Procedure J2264

“Chassis Dynamometer Simulation of Road Load Using Coastdown Techniques”

- Improved J1263 Roll Dynamometer Procedure.
- 3-Term “Road Load” Coefficients.
- Written for “New Style” Electric Roll Dynamometers.
- Used in Conjunction with SAE Procedure J2263 (Track)

*****Applications for the EMS Wheel Torque-Meter*****

- Verification Measurement System of the “Actual” Roll Dynamometer “Road Load” used for EPA Emission Certification and Fuel Economy Rating.
- Precision Measurement & Analysis System for Improving Fuel Economy.
- Investigation into the Effects of the Restraint Systems used on the AWD/4WD Roll Dynamometers. Comparison and Insight into the Differences of the “Road Load” Coefficients on each Wheel.
- Alternative Drive Test for Determining “Road Load” instead of a Coastdown Test.

*****Application for the EMS Wheel Torque-Meter*****

Verification System for the “Actual” Roll Dynamometer “Road Load”:

- Can be used with SAE Recommended Practices: J1263, J2263 & J2264.
- Can be used with Buckley ABCD Test Track with Anemometer Software & Buckley ABCD Roll Dyno Software.
- Can be used on Twin Roll, Single Roll & 4WD Dynamometers.
- Allows Coastdown Compatibility Analysis for Roll Dynos & Test Tracks.

*****Application for the EMS Wheel Torque-Meter*****

Measurement System for Improving Fuel Economy:

- Accurate Measurement of Parasitic Horsepower Losses Due to: *Chassis Friction, Tire Rolling Resistance & Aerodynamic Drag.*
- The Ability to Model the Dynamometer to Simulate Forces Acting on the Vehicle During Normal Road Operation with Various Road Grades.
- Investigations into “Actual” Vehicle Passing Push/Pull and Underbody Turbulences.
- Investigations into “Actual” Tire Rolling Resistance on Different Road Surfaces.

Shortcomings of SAE Procedure J2264:

Current Scope of J2264, Only Applies to:

“Two-Wheel Drive Vehicle Operation and a Single Axle Electric Roll Dynamometer”.

Problems Exist With Application to:

- AWD/4WD Vehicles
- AWD/4WD Roll Dynamometers
- Hybrid-Electrics Vehicles
- Vehicles with **C**ontinuously **V**ariable **T**ransmissions

Appendixes to be created and added to J2264:

- A Basic Discussion on ETW (Equivalent Test Weight).
- AWD/4WD Chassis Roll Dynamometer Types and Specifications for use with J2264.
- AWD/4WD Roll Dynamometer Restraint Systems and Philosophies.
- Application Notes and ETW Multipliers for AWD/4WD Vehicles on AWD/4WD Dynamometers.

Ongoing Research for J2264 Appendixes:

- AWD/4WD Roll Dynamometer Types and Specifications.
- AWD/4WD Vehicle Restraint Systems.
- AWD/4WD “Hard” and “Soft” Coupling Modes and their Effects on the Different Dynamometer Types.
- The Problem of Dynamometer “Motoring” on the Front Wheel Rolls.

*****Application for the EMS Wheel Torque-Meter*****

Investigation into the Restraint Systems used on the AWD/4WD Roll Dynamometers:

- Comparison and Insight into the Differences of Road Load Coefficients on each Wheel.
- Measurement of Vehicle Coastdown Target Load Error for each Speed Interval.
- Ability to Determine the Frictional Force Coefficients a_0 , b_0 & c_0 of the Dyno/Vehicle Combination.

Future Considerations and Possibilities for J2264:

- Development of a N.I.S.T. Traceable Roll Dynamometer Calibrator for Verification of the Actual “Dynamometer Road Load” Settings.
- Alternative “Drive” Test for Determining “Road Load” instead of the Current “Coastdown” Test

*****Application for the EMS Wheel Torque-Meter*****

Alternative Drive Test for Determining “Road Load”:

- Solves the Problems with Coasting CVT Transmissions.
- Removes the Repeatability Problems Related to the Variability of “Spin Loss” Associated with Coasting Some Automatic Transmissions.
- Possible Use for the Hybrid Electrics.
- Allows a Shorter Test Track to be Used to Determine “Road Load” for Vehicle Emissions Certification.

Contact Information

Paul Morgan

Engineered Measurement Systems, Inc.

Phone: 313-274-9100

Fax: 313-274-9102

E-mail: pmorgan@emstorque.com

Website: www.emstorque.com