

Today's Test Facility Technology and Opportunities for Modernization

Automotive Testing Expo
24 October 2008

Michael Doiron
Aiolos Engineering Corporation



AIOLOS 

Presentation Topics

- Test Facility Capability Trends
- Specific Upgrade Opportunities
- Project Examples

Needs & Capabilities

	Facility Type			
	Aerodynamic Wind Tunnel	Aeroacoustic Wind Tunnel	Climatic Wind Tunnel	Climatic Chamber
Flow Quality	✓	✓		
Ground Simulation	✓	✓		
High Speed	✓	✓		
Hot / Cold			✓	✓
Humidity			✓	✓
Low Noise		✓		
Snow / Rain			✓	✓

Needs & Capabilities

	Facility Type			
	Aerodynamic Wind Tunnel	Aeroacoustic Wind Tunnel	Climatic Wind Tunnel	Climatic Chamber
Flow Quality	✓	✓	✓	
Ground Simulation	✓	✓	✓	
High Speed	✓	✓	✓	
Hot / Cold			✓	✓
Humidity			✓	✓
Low Noise		✓	✓	
Snow / Rain			✓	✓

Reasons for Upgrades

- Obsolete Equipment
- Health & Safety, Environmental
- New Test Requirements
- New Test Capabilities

Test Capability Trends

Aerodynamics & Acoustics

- Higher Air Speed
- Flow Quality
- Axial Pressure Gradient
- Nozzle Size
- Ground Simulation

Test Capability Trends

Humidity Control

- Better control at colder temperatures
- Improved injection and control schemes
- Retrofits are feasible

Test Capability Trends

Rain Simulation

- Improved schemes for control of flow rates and droplet sizes



Test Capability Trends

Snow Simulation

- Control of both quality and quantity
- Ongoing development of systems



Test Capability Trends

Vehicle Exhaust System

- Enhanced dynamic response for extreme drive cycles
- Dilution damper control

Test Capability Trends

Flexible Nozzles

- Variable nozzle outlet geometry and air speeds
- Higher productivity
- Retrofits are feasible

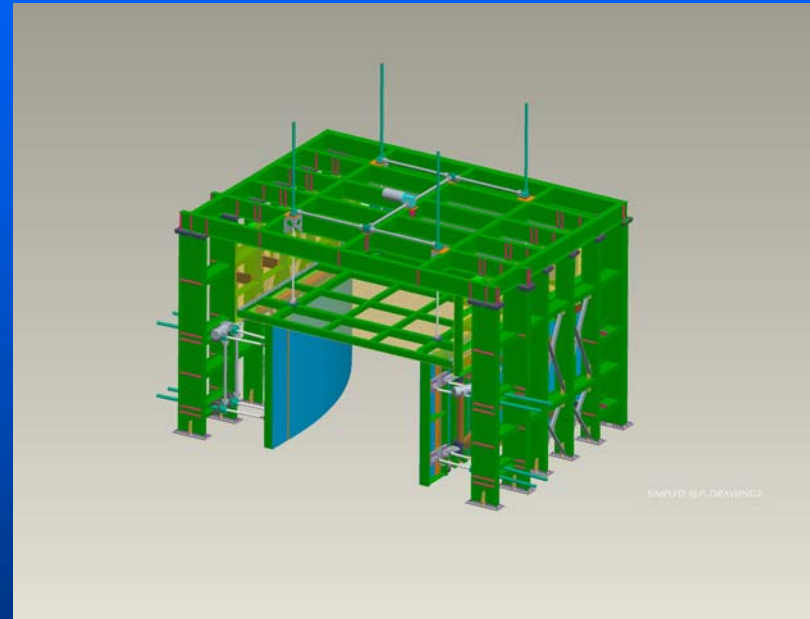

Project Examples



Land Rover CWT Upgrade

- Nozzle Size: was 11 m², now 6.9 m²
- Max. Air Speed: was 150 km/hr, now 220 km/hr
- Temperature Range: -32 °C to + 55 °C
- Fans: 4.8 m dia., 800 kW
- Dynamometer: 2WD (150 kW) becomes 4WD
- Cooling Capacity: 1250 kW
- Replace secondary system (was TCE, now Dynalene)

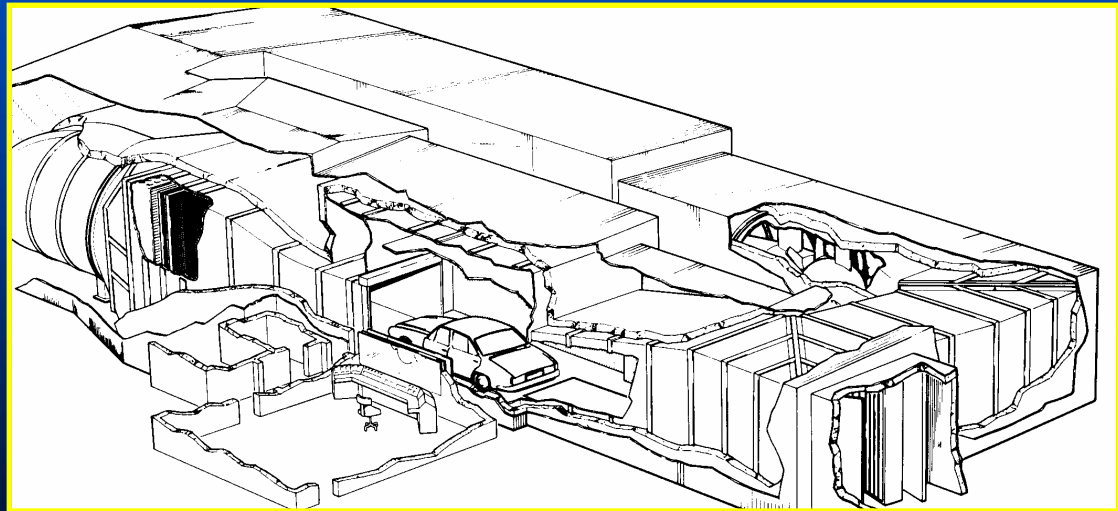

Project Examples

VOLVO

Aero/Thermodynamic Wind Tunnel

Original:

- Max Air Speed: 200 km/h
- Temperature Range: 20 °C to 60 °C
- Dynamometer: 100 kW
- Solar Simulation System

Phase 1 Upgrade (2001):

- Test Section Insert (250 km/hr)
- BL Removal System

Phase 2 Upgrade (2006):

- Fan & Drive (250 km/hr)
- 5 Belt RRS & BL system

